

INSTRUCTION
MANUAL

MEMS Digital Portable Vertical Inclinator (USB-C) From Serial DRI-1000



CE FC

GEOSENSE

CONTENTS

1. VERSION CONTROL	2
2. INTRODUCTION	2
2.1. GENERAL DESCRIPTION	3
2.2. THEORY OF OPERATION	4
2.3. THE MEASUREMENT OF INCLINATION	6
2.4. CONVENTIONS	6
3. CONFORMITY	7
4. MARKINGS	10
5. DELIVERY	11
5.1. PACKAGING	11
5.2. HANDLING	11
5.3. INSPECTION/FUNCTIONALITY CHECK READINGS	11
5.4. STORAGE	11
6. OPERATION	12
6.1. SYSTEM COMPONENTS	12
6.2. BATTERY CHARGING	14
6.3. INSTALLING THE INCLINOMETER APPLICATION ON THE ASD	15
6.4. SYSTEM ASSEMBLY AND OPERATION (QUICK GUIDE)	16
6.5. INCLOPRO SOFTWARE APPLICATION FOR ANDROID DEVICES	25
6.5.1. HOME SCREEN	25
6.5.2. SEARCHING FOR AN INCLINOMETER SYSTEM	26
6.5.3. SETTING UP A SITE	27
6.5.4. ADDING A BOREHOLE	28
6.5.5. SETTINGS	29
6.5.6. TAKING READINGS (ALSO DETAILED IN SECTION 6.4)	30
6.5.7. TAKING READINGS SCREEN	31
6.5.8. VIEWING DATA	35
6.5.9. DATA TRANSFER	42
7. DATA HANDLING	44
7.1. DATA FORMAT	44
7.2. DATA REDUCTION	46
7.3. TEMPERATURE CONSIDERATIONS	48
8. MAINTENANCE	49
9. TROUBLESHOOTING	50
10. SPARE PARTS	50
11. RETURN OF GOODS	51
11.1. RETURNS PROCEDURE	51
11.1.1. CHARGEABLE SERVICE OR REPAIRS	51
11.1.2. WARRANTY CLAIM	51
11.2. PACKAGING AND CARRIAGE	51
11.3. TRANSPORT & STORAGE	51
12. LIMITED WARRANTY	52

1. VERSION CONTROL

Version	Date	Author	Approved	Released
V1.1	29/07/25	CL	GC	CL
V1.2	04/12/25	CL		

2. INTRODUCTION

This manual is intended for all users of the **Portable Inclinometer Systems** manufactured by **Geosense®** and provides information on their operating principles, conventions, operation and maintenance.



**It is VITAL that all personnel responsible
for the use of the Portable Inclinometer
READ and UNDERSTAND
this manual, prior to working with the equipment**



2.1. General Description

The **Geosense® Portable Inclinometer** equipment is an environmentally sealed assembly used to accurately and reliably register changes of inclination within specialist inclinometer casing. The assembly comprises a probe connected to a graduated cable that is held on a cable reel. The reel is Bluetooth-enabled for wireless connection to an Android Smart Device (ASD).

Inclinometer Casing can be installed or included in many types of structures and monitoring regimes. It can be within vertical, inclined or horizontal installations.

Common applications include the following:

- Embankment stability monitoring
- Stability of retaining walls
- Dam monitoring
- Horizontal pile testing
- Slope stability and landslide monitoring
- Storage tank base settlement

Particular features of Geosense® Portable Inclinometer Systems are:

- Reliable long-term performance
- Ruggedness; suitable for demanding environments
- Bluetooth, cable-free interconnection
- High accuracy
- Digital output and full EMI shielding
- Designed with the user in mind

The **Geosense® Inclinometer** sensors are based upon Micro Electro-Mechanical Systems technology (MEMS). The MEMS accelerometer sensors in the Inclinometer Probe are configured to measure changes in rotation (tilt or inclination). The probe contains two sensors mounted orthogonally to measure inclination in perpendicular directions (A axis and B axis). Electronic circuitry within the probe interrogates its sensor, and the corresponding output is converted from an Analogue to a Digital signal, making it particularly suitable for the demanding environments of geotechnical and civil engineering applications.

Geosense® Inclinometer probes carry 'onboard' calibration data so that probe/cable/reel /readout combinations are all interchangeable. Each element also has a unique serial number.

Portable Inclinometer Systems are commonly used where monitoring is infrequent or automated monitoring is too expensive. These systems are used to determine the inclination of the inclinometer casing at intervals along its length (commonly 0.5m or 2ft). This information is processed to generate a profile of the inclinometer casing, with respect to vertical and subsequent profiles being compared with each other to detect changes.

2.2. Theory of Operation

Special tubes, commonly referred to as Casing or Access Tubes, are installed into or fixed onto the structure or formation to be monitored (see **Geosense® Inclinometer Casing** Installation Manual).

Inclinometer casing is specially machined ABS tube that has 4 equally spaced, parallel 'keyways' in its inner surface and a reference 'rib' on its outer surface. The inclinometer casing is designed to move with the structure into which or onto which it is fixed, if the structure changes. Casing is best installed so that one pair of keyways is parallel to the 'expected' direction of movement, and this will be denoted as the 'A' direction (primary direction).

The Portable Inclinometer System is used to detect and quantify any changes in the shape of the installed casing. For vertical or inclined casing, changes in the horizontal direction can be detected, and for horizontal casing, changes in the vertical direction can be detected. The inclinometer probe, connected to its cable, is inserted into the inclinometer casing with its wheels located in the A+/A- keyways (Figure 1).

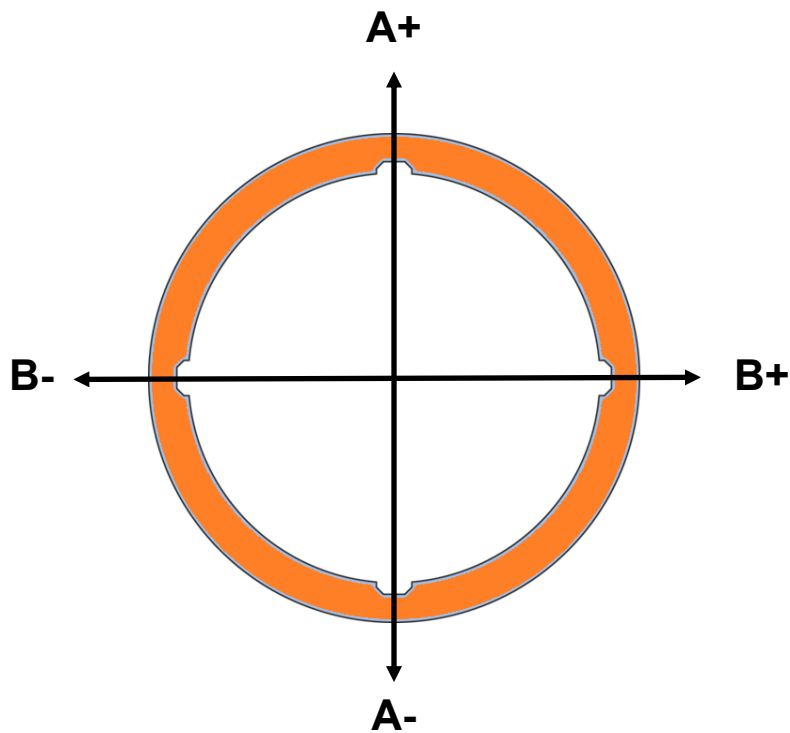

Figure 1: Schematic of Inclinometer Casing Keyways

The **Geosense® Digital Inclinometer Probe** houses a pair of extremely sensitive Micro Electro-Mechanical System (MEMS) Tilt Sensors. These devices detect the angle of the probe with respect to the vertical. The two sensors are mounted orthogonally so that they can measure the verticality of the probe in two perpendicular directions, simultaneously. These directions are commonly termed the 'A' axis and the 'B' axis (Figure 2).

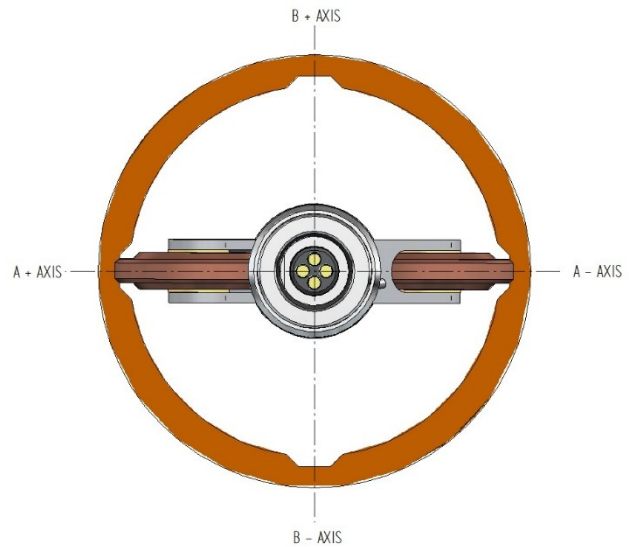

Figure 2: 'A' Axis and 'B' Axis

The probe is attached to a highly robust and flexible support/signal cable that is, in turn, connected to a portable cable reel. The cable reel includes a Bluetooth communication module and a rechargeable battery power supply. The cable is fitted with 'crimped' cable markers that securely identify 0.5m (or 2ft) intervals along its length.

The Cable Reel Bluetooth module is used to connect to an **Android Smart Device (ASD)** to the probe. The software on the ASD first connects to the reel modules and then to the probe at the end of the cable. Once connected, the ASD displays the inclination of the probe in mm.

The displayed values represent the value of ' $L \sin \theta$ ' (Figure 3) in two perpendicular directions, A and B.

In order to generate a profile of an installed inclinometer casing, a series of interconnected readings is recorded. The probe is oriented so that the upper wheel is facing the direction of expected movement and inserted into the casing with the wheels in the corresponding grooves. It is lowered to the base of the casing and suspended on one of the cable markings.

A reading is recorded, and the probe is lifted by the distance equivalent to its 'gauge length' (Figure 3) and another reading is taken. This process is repeated up the full length of the casing.

In order to eliminate system 'face' difference (very small manufacturing and assembly considerations), the sequence is repeated with the probe turned through 180 degrees in the casing.

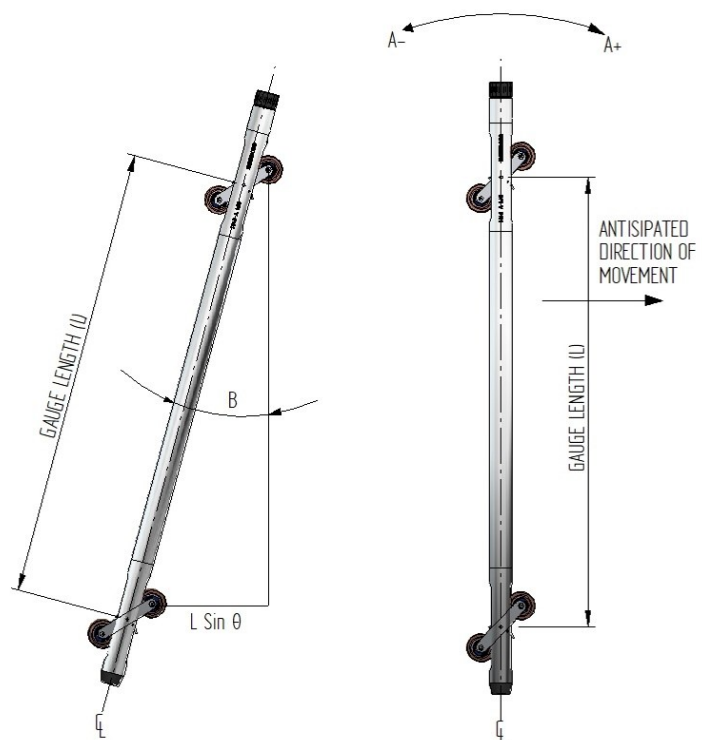

Figure 3: $L \sin \theta$ and Roll Planes of Measurement

2.3. The Measurement of Inclination

To minimise the issue of 'human error', **Geosense®** has introduced the option of 'Automatic Inclinometer Data Acquisition' into its proprietary software. This utilises the effectiveness of the sensors and the intelligence of the ASD to allow the software to determine when the readings are considered stable, record them, instruct the user to move to the next reading elevation and sense when this has been carried out.

Essentially, the user has only to respond to a series of audible prompts, thereby almost removing the risk of errors caused by distraction or haste.

The uppermost wheel denotes the 'A+' probe direction (also engraved on the Probe).

When the probe is inclined with its upper wheelset toward the '+' direction (A or B), the reading of inclination is '+'.

A '+' change in the computed Displacement indicates a change in the inclination in the '+' direction.

2.4. Conventions

In most cases, a survey is conducted from the base of the inclinometer tube towards the top and assumes the base of the tube is 'beyond the zone of expected movements', even if the movements are to be computed from the 'Top Down'. There are some circumstances where this assumption does not apply. Surveys are almost NEVER conducted from the top towards the base.

3 surveys are normally conducted to establish the Base Data File (Initial Data). The values are either averaged to generate the Base Data or a 'Mean Data Set' is selected to represent the Base Data.

3. CONFORMITY

Simplified EU Declaration of Conformity for Radio Equipment Directive (2014/53/EU)

<p><i>Geosense Ltd</i> tímto prohlašuje, že tento Portable MEMS Inclinometer je ve shodě se základními požadavky a dalšími příslušnými ustanoveními směrnice 2014/53/EU.</p>
<p>Undertegnede, <i>Geosense Ltd</i> erklærer herved, at følgende udstyr Portable MEMS Inclinometer overholder de væsentlige krav og øvrige relevante krav i direktiv 2014/53/EU.</p>
<p>Hiermit erkläre, <i>Geosense Ltd</i> dass sich das Gerät Portable MEMS Inclinometer in Übereinstimmung mit den grundlegenden Anforderungen und den übrigen einschlägigen Bestimmungen der Richtlinie 2014/53/EU befindet.</p>
<p>Käesolevaga kinnitab, <i>Geosense Ltd</i> seadme Portable MEMS Inclinometer vastavust direktiivi 2014/53/EL põhinõuetele ja nimetatud direktiivist tulenevatele teistele asjakohastele sätetele.</p>
<p>Hereby, <i>Geosense Ltd</i> declares that Portable MEMS Inclinometer is in compliance with the essential requirements and other relevant provisions of Directive 2014/53/EU.</p>
<p>Por medio de la presente <i>Geosense Ltd</i> declara que el Portable MEMS Inclinometer cumple con los requisitos esenciales y cualesquiera otras disposiciones aplicables o exigibles de la Directiva 2014/53/UE.</p>
<p>ΜΕ ΤΗΝ ΠΑΡΟΥΣΑ, <i>Geosense Ltd</i> ΔΗΛΩΝΕΙ ΟΤΙ Portable MEMS Inclinometer ΣΥΜΜΟΡΦΩΝΕΤΑΙ ΠΡΟΣ ΤΙΣ ΟΥΣΙΩΔΕΙΣ ΑΠΑΙΤΗΣΕΙΣ ΚΑΙ ΤΙΣ ΛΟΙΠΕΣ ΣΧΕΤΙΚΕΣ ΔΙΑΤΑΞΕΙΣ ΤΗΣ ΟΔΗΓΙΑΣ 2014/53/ΕΕ.</p>
<p>Par la présente, <i>Geosense Ltd</i> déclare que l'appareil Portable MEMS Inclinometer est conforme aux exigences essentielles et aux autres dispositions pertinentes de la directive 2014/53/UE.</p>
<p>Con la presente, <i>Geosense Ltd</i> dichiara che questo Portable MEMS Inclinometer è conforme ai requisiti essenziali ed alle altre disposizioni pertinenti stabilite dalla direttiva 2014/53/UE.</p>
<p>Ar šo <i>Geosense Ltd</i> deklarē, ka Portable MEMS Inclinometer atbilst Direktīvas 2014/53/ES būtiskajām prasībām un citiem ar to saistītajiem noteikumiem,</p>
<p>Šiuo <i>Geosense Ltd</i> deklaruoja, kad šis Portable MEMS Inclinometer atitinka esminius reikalavimus ir kitas 2014/53/ES Direktyvos nuostatas.</p>
<p>Hierbij verklaart, <i>Geosense Ltd</i> dat het toestel Portable MEMS Inclinometer in overeenstemming is met de essentiële eisen en de andere relevante bepalingen van richtlijn 2014/53/EU.</p>
<p>Hawnhekk, <i>Geosense Ltd</i>, jiddikjara li dan Portable MEMS Inclinometer jikkonforma mal-ħtiġijiet essenzjali u ma provvedimenti oħrajn rilevanti li hemm fid-Dirrettiva 2014/53/EU.</p>
<p>Alulírott, <i>Geosense Ltd</i> nyilatkozom, hogy a Portable MEMS Inclinometer megfelel a vonatkozó alapvető követelményeknek és az 2014/53/EU irányelv egyéb előírásainak.</p>

Simplified EU Declaration of Conformity for Radio Equipment Directive (2014/53/EU)

<p>Niniejszym <i>Geosense Ltd</i> oświadcza, że Portable MEMS Inclinometer jest zgodny z zasadniczymi wymogami oraz pozostałymi stosownymi postanowieniami Dyrektywy 2014/53/UE.</p>
<p><i>Geosense Ltd</i> declara que este Portable MEMS Inclinometer está conforme com os requisitos essenciais e outras disposições da Directiva 2014/53/UE.</p>
<p><i>Geosense Ltd</i> izjavlja, da je ta Portable MEMS Inclinometer v skladu z bistvenimi zahtevami in ostalimi relevantnimi določili direktive 2014/53/EU.</p>
<p><i>Geosense Ltd</i> týmto vyhlasuje, že Portable MEMS Inclinometer spĺňa základné požiadavky a všetky príslušné ustanovenia Smernice 2014/53/EÚ.</p>
<p><i>Geosense Ltd</i> vakuuttaa täten että Portable MEMS Inclinometer tyyppinen laite on direktiivin 2014/53/EU oleellisten vaatimusten ja sitä koskevien direktiivin muiden ehtojen mukainen.</p>
<p>Härmed intygar <i>Geosense Ltd</i> att denna Portable MEMS Inclinometer står i överensstämmelse med de väsentliga egenskapskrav och övriga relevanta bestämmelser som framgår av direktiv 2014/53/EU.</p>
<p>Hér með lýsir <i>Geosense Ltd</i> yfir því að Portable MEMS Inclinometer er í samræmi við grunnkröfur og aðrar kröfur, sem gerðar eru í tilskipun 2014/53/EU.</p>
<p><i>Geosense Ltd</i> erklærer herved at utstyret Portable MEMS Inclinometer er i samsvar med de grunnleggende krav og øvrige relevante krav i direktiv 2014/53/EU.</p>
<p>Noi, <i>Geosense Ltd</i>, declarăm pe propria noastră răspundere că produsul Portable MEMS Inclinometer este în conformitate cu cerințele esențiale și celelalte prevederi aplicabile ale Directivei 2014/53/UE.</p>

FCC Compliance Statement (47 CFR § 15.19):

Unique Identifier: Geosense Ltd "Portable Inclinometer"

This device complies with part 15 of the FCC Rules. Operation is subject to the following conditions:

1. This device may not cause harmful interference, and
2. this device must accept any interference received, including interference that may cause undesired operation.

Responsible Party – U.S. Contact Information:

iCertifi
2445 NE Division St, Ste 202
Bend, Oregon 97703 USA

Tel: +1 866 885 4575
Internet: www.iCertifi.com

ISED Compliance Statement (RSS-Gen 8.4):

This device complies with Innovation, Science and Economic Development Canada's license-exempt RSS(s). Operation is subject to the following two conditions:

1. This device may not cause interference, and
2. this device must accept any interference, including interference that may cause undesired operation of the device.

Responsible Party – Canada Contact Information:

Americas Compliance Consulting LLC dba iCertifi
380 Wellington Street, Tower B, 6th Floor, Suite 656,
London, Ontario, N6A 5B5, Canada

Tel: +1 866 885 4575
Internet: www.icertifi.com

4. MARKINGS



Figure 4: Geosense® Inclinometer Markings

All **Geosense® Digital MEMS Inclinometer Systems** are labelled with the following information, and each component carries a unique identification serial number that is included on the labels.

- **Manufacturer's telephone number and website address**
- Product group: **MEMS Inclinometer System**
- Product type: **MEMS Inclinometer System**
- Model: **Vertical**
- Range: **+/- 30°**
- Orientation: **Vertical – Biaxial**
- Serial numbers: Probe: **DPI (V, I, H) XXXX** Cable Reel: **DRI XXXX**
- **CE mark**
- **FCC ID**
- **WEEE mark**

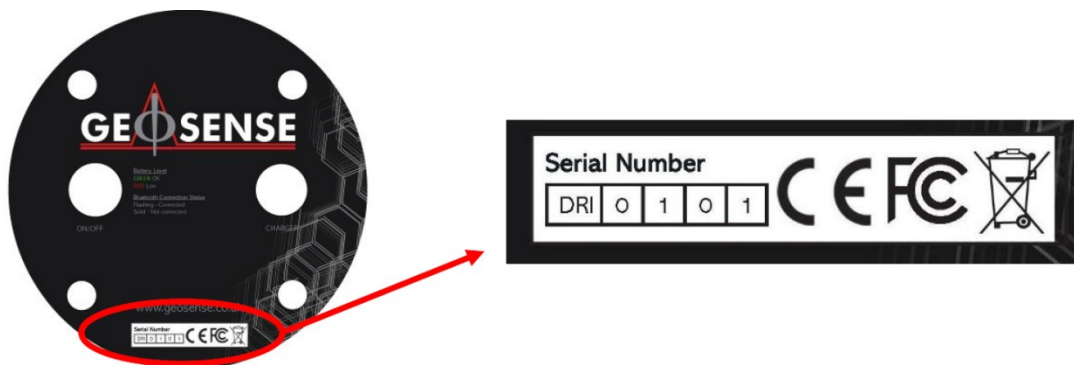

5. DELIVERY

This section should be read by all users of equipment manufactured by **Geosense®**.

5.1. Packaging

Geosense® Inclinometers are packed for transportation to site. Packaging is suitably robust to allow normal handling by transportation companies. Inappropriate handling techniques may cause damage to the packaging and the enclosed equipment. The packaging should be carefully inspected upon delivery, and any damage **MUST** be reported to both the transportation company and **Geosense®**.

5.2. Handling

Whilst they are a robust device, **Geosense® Inclinometer Systems** are precision measuring instruments. They, and their associated equipment, should always be handled with care during transportation, storage and installation.

Once the shipment has been inspected (see 5.3), it is recommended that the equipment remain in its original packaging for storage or onward transportation.

5.3. Inspection/Functionality Check Readings

It is important to check all the equipment in the shipment as soon as possible after taking delivery and well before installation is to be carried out. Check that all the components detailed in the documents are included in the shipment. Check that the equipment has not been physically damaged.

Geosense® Inclinometer Probes are supplied with individual calibration sheets that include their serial numbers, and these are shipped with the equipment.

Wherever possible, it is suggested that the Inclinometer Systems should be functionally checked soon after arrival to ensure they have not been damaged during transportation. This is a basic 'out of the box' functional check. To carry out the check, follow the initial steps detailed in Section 6 of this manual.

5.4. Storage

All equipment should be stored in an environment that is protected from direct sunlight and extreme heat. It is recommended that equipment be stored in a dry environment with caps in place, in an area free from rodents, as they have been known to damage cables and cases. Batteries should be charged regularly, even when the equipment is not in use, to maintain their capacity and life expectancy.

Temporary Storage

After reaching 0% charge, recharge the unit within 1-2 months to prevent permanent battery damage.

Long-Term Storage

If the probe is to be stored for long periods, a light coat of lubricant on the moving parts is advisable. Before storage, fully charge the reel and recharge the unit every 3-6 months to maintain battery health.

6. OPERATION

This section of the manual is intended for all users of portable **Geosense® Inclinometer** equipment and is intended to provide guidance with respect to its use.

It must be remembered that no two installations will be the same, and some 'fine tuning' of the following procedures will inevitably be required to suit specific site conditions.

6.1. System Components

Illustrated below (Figure 5) are the components of the **Geosense® Inclinometer Readout System**.



Figure 5: System Components

A INCLINOMETER PROBE

A slimline probe in which the sensors and electronics are housed. 2 pairs of wheels provide stability and maintain alignment. Waterproof connector for attaching the cable.

B CABLE

A rugged and flexible cable for electrical connection to the probe. Fitted with secure cable markers at 0.5m (or 2ft) centres to accurately position the probe inside the inclinometer casing at defined and repeatable locations.

C CABLE REEL and CHARGER

A convenient carrying facility for the graduated cable. Included in the reel body are the main inclinometer probe power supply, and the Bluetooth communication module. The battery is charged by connecting the supplied charger to the charging socket on the face of the reel. Clips are fitted to the reel for convenient probe transportation.

D ASD

A ruggedised, GSM-enabled Android device for reading, recording, displaying and transmitting the data from the inclinometer probe. Its internal battery is charged using the supplied micro-USB charger/power supply.

E CABLE SUPPORTS

For fitting into the top of all **Geosense® Inclinometer** casing (and the casing from most other manufacturers), these are used to position the probe at a repeatable location within the casing.

F CAPS

Protection for the electrical connections and the whole monitoring package.

G CARRYING CASES

Anodised aluminium hard case for the inclinometer probe, readout and accessories. Hard-wearing fabric case with shoulder strap for the cable reel and its charger.

H SOFTWARE

Data presentation software for handling and presenting recorded values. Provides easily interpreted graphical presentation of the field readings, together with data management tools.

6.2. Battery Charging

Whilst the Reel and ASD have long battery lives, fully charging the equipment prior to visiting site is strongly recommended.

As with most handheld equipment, the ASD can be easily charged using most USB chargers and power banks. However, the reel required a main 100-250 VAC supply.

- 1) Remove the ASD, USB cable and charger from the hard case. Connect the USB connector to the ASD and the standard USB plug to the charger.

The charger is supplied with various mains plug adaptors. Select and fit the adaptor appropriate to the available mains electrical sockets.



- 2) Connect the charger to a mains electrical supply, switch it on and allow the ASD to charge fully.

- 3) The reel utilises the same charger as the ASD.

Remove the cap from the reel connector and fit the charger lead to the reel.



- 4) Connect the charger to a mains electrical supply, switch it on and allow the readout to charge fully – indicated by a solid green light.

When in use and on charge, the power button of the inclinometer reel will illuminate depending on the status of the system. The reel has the legend printed on it so the user can understand the status of the reel.

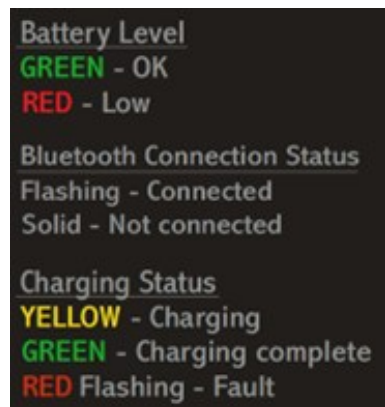

6.3. Installing the Inclinometer Application on the ASD

It is necessary to install the **Geosense® Software Inclinometer Application** onto the ASD from the Google® Play Store. This will ensure the latest version is downloaded.

For this, it will be necessary to establish an 'Identity' with Google® and establish a connection to the internet.

- 1) Start the ASD and tap on the Google® Play Store. This will be on the Home Screen.

At this point, it will be necessary to either sign in to a Google® account or create an account.

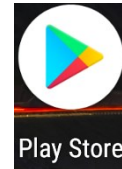

- 2) Once logged in, search for the **Geosense® Inclinometer Application** named 'IncloPRO'.



- 3) Tap on the icon to open the app details.
- 4) Tap "install".
- 5) Tap "Accept & Download" after reviewing the list of permissions.
- 6) The **IncloPRO** icon will normally appear on the ASD Home Screen. If the icon does not appear, locate the icon in one of the App folders (it can then be moved to the Home Screen for convenience).

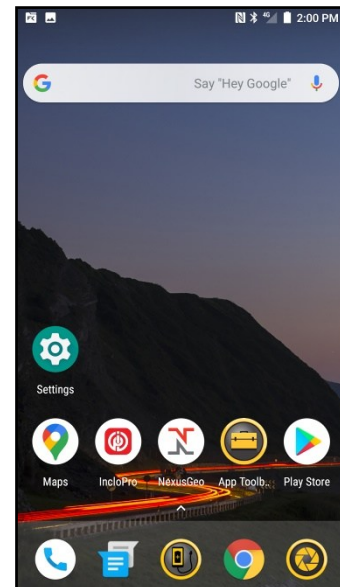

- 7) App permissions must now be set in order for the ASD to connect to the reel. This can be accessed through the phone settings:

Settings → Apps & Notifications → App Info
→ Select 'IncloPRO' app → Permissions
→ Allow Location and Storage Permissions

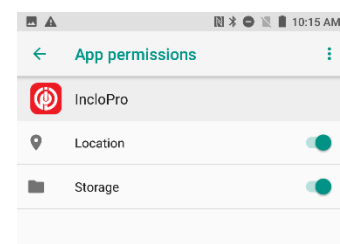

- 8) The app is now ready to connect to a reel.

6.4. System Assembly and Operation (Quick Guide)

Most of the components of the **Inclinometer Readout System** are contained within the hard carry case. Only the cable and the reel are housed within the soft case.

- 1) Remove the probe from the hard case and remove the black cable connector cover.
- 2) Remove the cable reel from its case and remove the cable connector cover.



- 3) Taking note of the machined mating 'D' alignment in the plug and socket and the alignment markers, carefully connect the cable to the probe. Place the probe in a position where it cannot fall or be damaged.



- 4) Remove the ASD from the hard case and turn it on (for detailed ASD specific instructions, see section 6.5).



- 5) Press the ON/OFF button on the side of the reel, holding until its light switches on. This shows that the power is on with a **GREEN** light indicating an adequate battery level and a **RED** light indicating insufficient battery (the reel would need to be charged before monitoring is carried out).



6) On the ASD, check that the 'Bluetooth' symbol is showing in the top bar (by default it is set to turn on, but if it is not, go to the ASD settings and turn it on).



7) Open the **Geosense® Inclinometer Application, 'IncloPro'**. For detailed App operation instructions, see Section 6.5.



8) Tap the 'Connections' icon on the lower menu bar to open the Connections page.



A list of 'Paired Reels' will be presented. Check that the serial number of the reel to be used is included in the list. If not, tap the 'SEARCH FOR NEW REEL' bar.

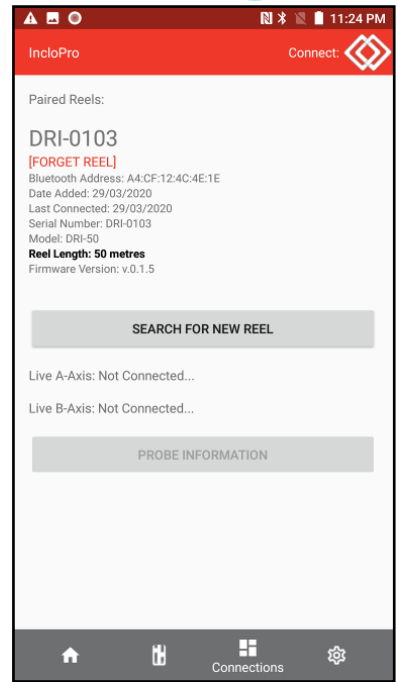

A list of all local Bluetooth devices will be presented on the screen. Scroll through the list to locate the serial number of the reel being used and tap on it to activate the pairing operation.

When using the app for the first time, it will be necessary to search for the reel to carry out this pairing operation. Once paired, the ASD memorises the configuration.

9) Tap the connect icon  to check the Bluetooth connection. When connected, the connection is confirmed by displaying the Reel battery condition and the Reel temperature.



In addition, live probe readings are shown on the screen, above the '**PROBE INFORMATION**' bar.

10) Tap the connect icon  to break the Bluetooth connection. It should return to an 'all white' colour.

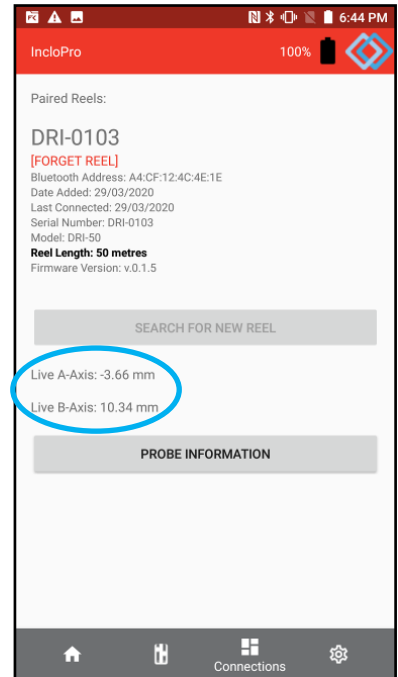

- 11) Remove the cover from the inclinometer access tube, if there is one (a secure cover is strongly recommended).
- 12) Identify the 'Primary' axis keyways in the tube, sometimes referred to as the 'A' or 'A+/A-' axis (this is usually the pair of keyways that are closest to the direction of expected movement). Since the **Geosense® Inclinometer** is Bi-axial, only this pair of keyways needs to be used.

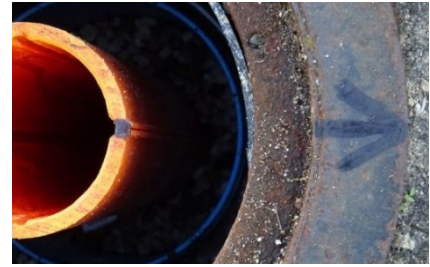

- 13) Release the brake screw on the side of the Cable Reel.



- 14) With one finger, push the lower wheelset so as to close it in towards the probe and insert it into the access tube, taking care that the wheels are located in the keyways.



- 15) Repeat this for the upper wheel set.

- 16) Carefully lower the probe into the access tube until it reaches the base of the tube, or the required depth.



**NEVER ALLOW
THE PROBE TO FREEFALL
DOWN THE TUBE**

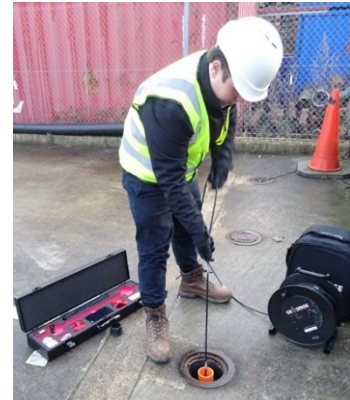

- 17) Select the appropriate 'Cable Support' from the hard case and push it into the access tube as shown. Ensure that it fits firmly and is pushed down to sit on one of the machined 'shoulders'.



- 18) Lift the cable until a marker can be positioned in the support, thereby maintaining the probe in suspension in the base of the tube. **The lowest reading must be recorded with the probe suspended, NOT resting on the bottom of the tube.**



19) Determine the depth of this first reading from the marks on the cable. Individual markers are 0.5m (or 2ft) apart with numeric indications at 5.0m (or 16ft) intervals.

20) Tap the connect icon  to disconnect the Bluetooth connection.

21) Tap the Boreholes icon  at the base of the screen.

22) Select the Site and Borehole from the lists. If a new Site or Borehole is needed, tap the Add icon  as required and fill in the necessary information (for more guidance, refer to Section 6.5).

23) With the probe positioned and suspended at the base of the Inclinometer tube, tap **TAKE READINGS**.

This will open the initial **Stabilising Page**.

Since any sensing system can be affected by temperature gradients over its electronics and their mountings, the **Geosense® App** automatically monitors the temperature inside the probe. If temperature changes are deemed to risk affecting the data, the App will display 'Probe Temperature Stabilising' and will display the current temperature.

The screen also displays the correct orientation of the probe.

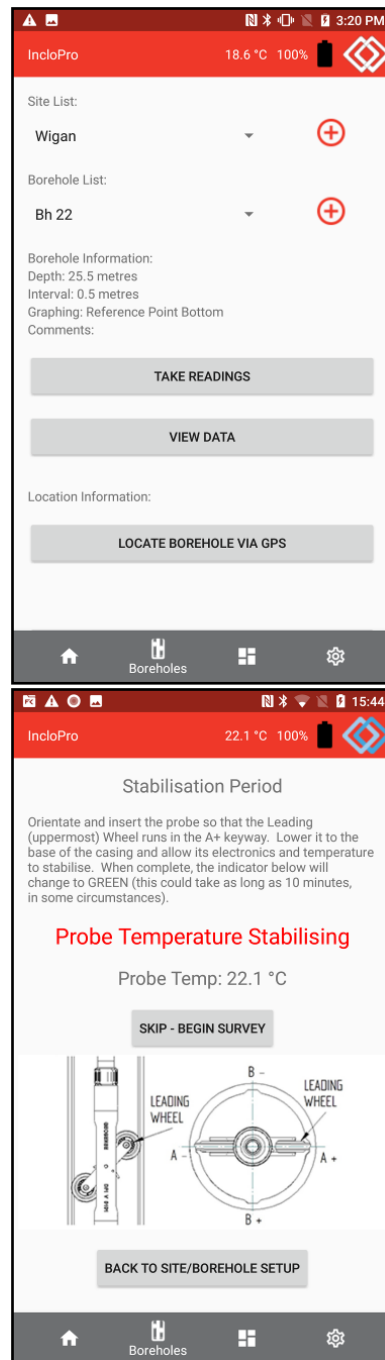

24) Once any temperature changes have reduced to an acceptable level, the screen indicates that the temperature has stabilised.

In exceptional circumstances, this period can be curtailed by tapping '**SKIP**' to advance to starting the Inclinometer survey.

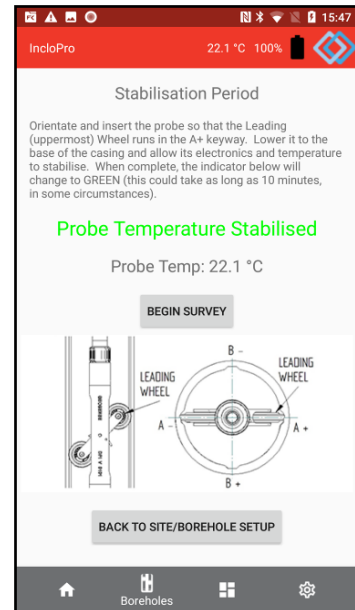

25) Begin the Inclinometer Survey.

Three values will be displayed in a large font on the screen: the inclination in the '**A**' direction, in line with the probe wheels; the inclination in the '**B**' direction, perpendicular to the wheels; and the Depth of the readings in meters.

The coloured bar between the axis readings and the depth indicates the reading stability. Pink and red colours indicate that the probe readings do not yet meet the required stability criteria, and **Green** indicates acceptable stability. The '**ACCEPT READING**' button also mimics the colour of the 'Reading Stability' bar.

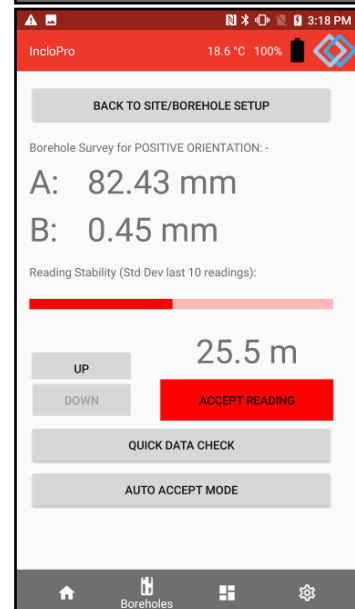

26) It is recommended that, to better control the quality and repeatability of the data, '**AUTO ACCEPT MODE**' is activated at this stage.

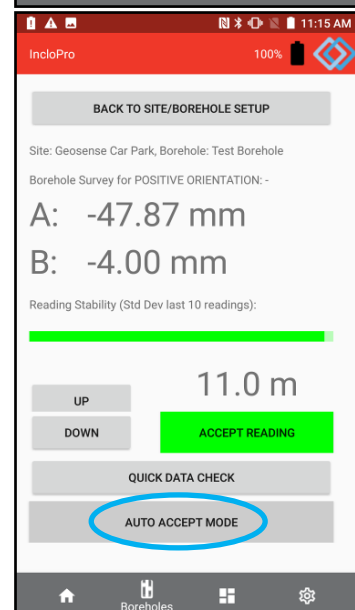

27) When the readings have stabilised, the '**Additional Readings**' counter is displayed and then the ASD records the values.

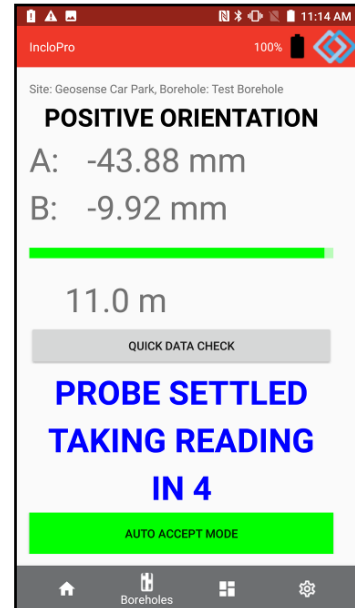

28) The display then changes the depth value to the next interval and prompts the user to move the probe and beeps loudly.

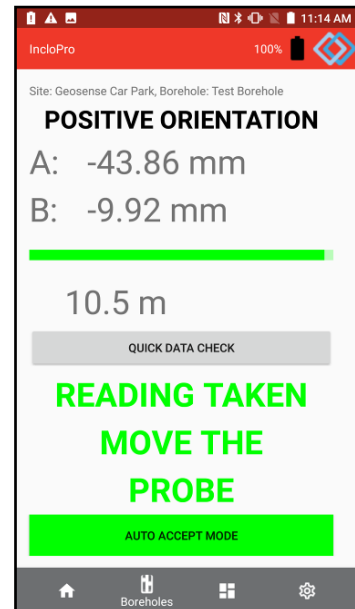

29) When the probe is moved, the beeping stops and the screen changes.

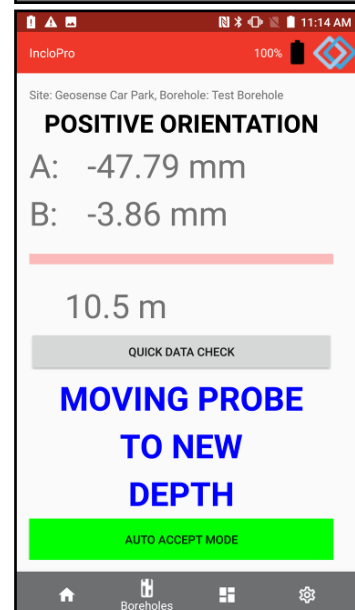

30) When the sensors detect the probe has been positioned at the next reading position, the screen changes as the readings stabilise.

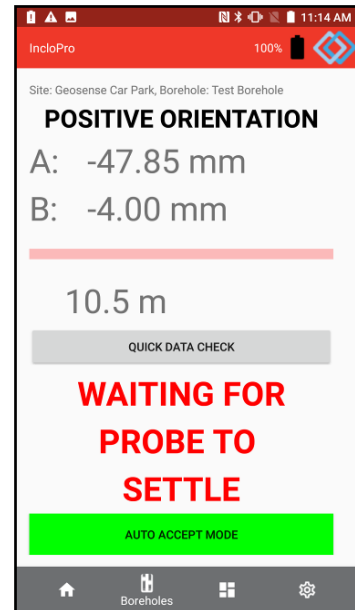

31) When the readings have stabilised the 'Additional Readings' counter is triggered and displayed. The ASD waits from the set period as the counter decreases, then records the values.

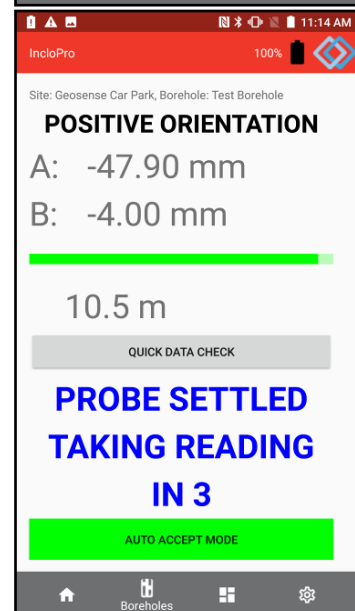

32) Repeat until the probe is sitting just under the cable support, on the 0.5m (of 2ft) marker.

33) When the ASD accepts the next reading, the App reverts to the **Manual Operation** and the screen displays an instruction to rotate the probe through 180 degrees.

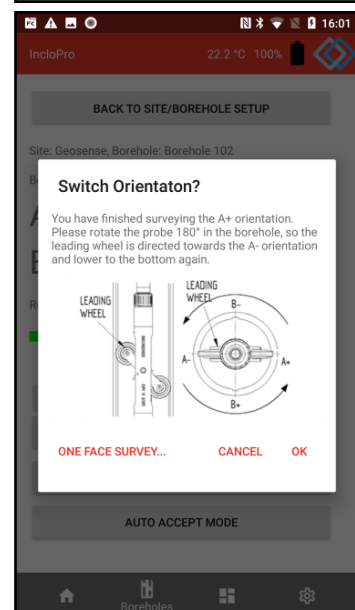

- 34) Hold onto the cable and carefully remove the cable support.
- 35) Lift the probe out of the tubing, hold it vertically and rotate it through **180 degrees** about its vertical axis so that the wheels are facing in the **opposite** direction.
- 36) Re-insert the probe into the same pair of keyways in the tubing, as described in step 12) to 14) above and lower it to the base of the tube.
- 37) Re-fit the cable support and lift the cable to sit the first cable marker in the support, as described above.



- 38) Tap **'OK'** on the ASD screen to begin recording readings from the 'Negative Orientation'

On the rare occasion a 'One Face Survey' is required, tap the screen to close the data file.

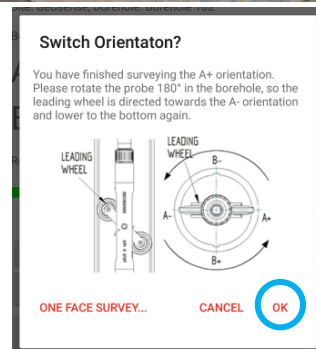

As the probe stabilises, a 'Checksum' reading will appear under each inclination reading. This value helps the user to assess the reliability of the readings by comparing the current reading with the corresponding reading that was recorded in the first half of the monitoring exercise. It is a comparison between the two electronic signals with the probe at the same depth, but rotated by 180 degrees.

This reading need not be small, but needs to show appropriate stability.

REPEAT STEPS 25 TO 32

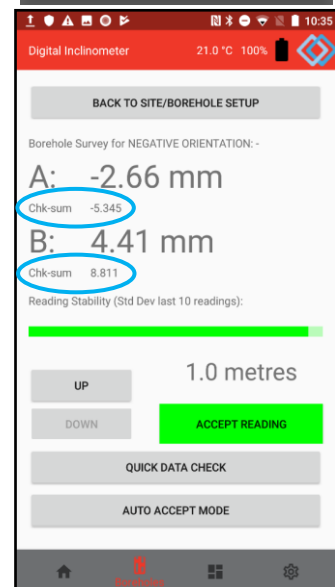

39) When the survey is complete, the ASD screen will prompt the operator to '**Save Survey**'. In addition, the operator's name can be added together with any specific site notes, particularly those that may have affected the readings.

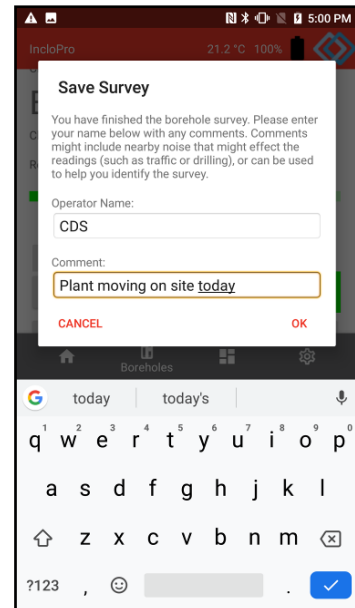

40) If the monitoring is complete, the cable should be wound onto the reel and should be disconnected from the probe. The end caps must be fitted to both the probe and the cable plug.

However, if monitoring is to continue at another location nearby, the cable should be wound onto the reel. The probe can remain connected to the cable with the probe fitted into the transport clips on the frame.

Care must be taken not to damage the cable and connector during transportation.



6.5. IncloPRO Software Application for Android Devices

The **Geosense® Portable MEMS Inclinometer System** is supplied with an ASD running an Android Operating System (AOS).

IncloPRO is a purpose-built software application, developed alongside the hardware, to utilise the features of the device as an inclinometer data logger (**IncloPRO** can be run on any Android device running an OS 8 or above and having a Bluetooth 'low energy' 4.2 facility).

Before running the **IncloPRO** application, it is recommended that the user familiarise themselves with the ASD, its controls and the Android OS. A separate manual for the ASD is supplied with the Inclinometer System.

The Inclinometer Probe is connected to cable; the cable is contained on the reel. The reel communicates with the ASD wirelessly via low-energy Bluetooth with a range of up to 10 metres.

Turn on the ASD and wait for its Home Page to load.



Ensure that Bluetooth communication is turned **ON** (for instructions, see the ASD manual).



To start the **IncloPRO** application, tap the icon.

6.5.1. Home Screen

Menu Icons at the base of the screen:



Home (current screen)



Boreholes – set up sites, inclinometers and run surveys



Connections – pair your Portable Inclinometer System with the App



Settings

Details of these subsequent menus are provided in this manual.

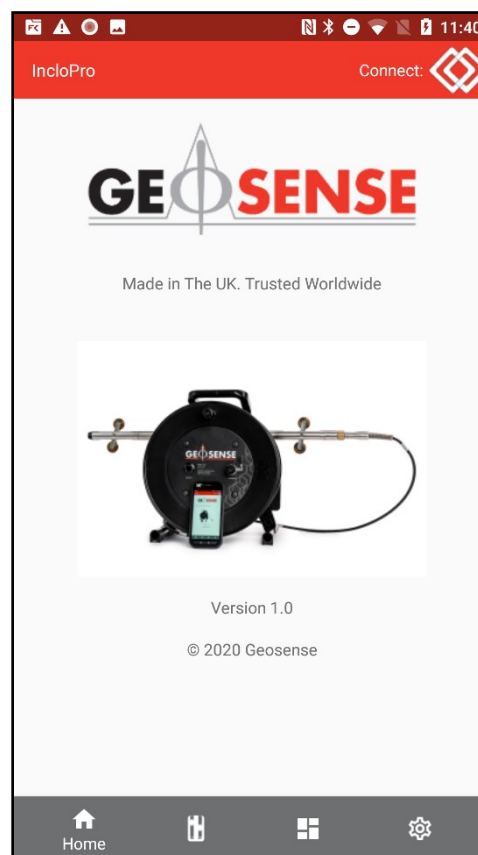

6.5.2. Searching for an Inclinometer System

Tap the Connections icon.

Connect the Probe to the Cable (see section 6.4). With the ASD within 10m of the reel (Bluetooth range), press the power button on the side of the reel. The button will show a **green** light (unless the reel battery is not charged) and make a bleep sound.

Tap **'SEARCH FOR NEW REEL'** on the screen. This will bring up a list of active Bluetooth devices nearby.

Look for a device with the Bluetooth name matching the serial number of the reel, for example **'DRI-0103'**.

If it is not visible, check the reel is switched on (green light around the button) and tap **REFRESH** on the Search Screen.

Tap on the device name, and the reel will appear as a paired reel on the connections screen.

Note: When selecting the device, it can take several seconds for the reel to pair and be shown as a paired device.

Having paired the reel with the app, tap the connect icon in the top right of the screen to connect to the device.



The light on the front of the reel will begin to flash. The icon will change to blue. The probe temperature and reel battery level will also be displayed in the app.

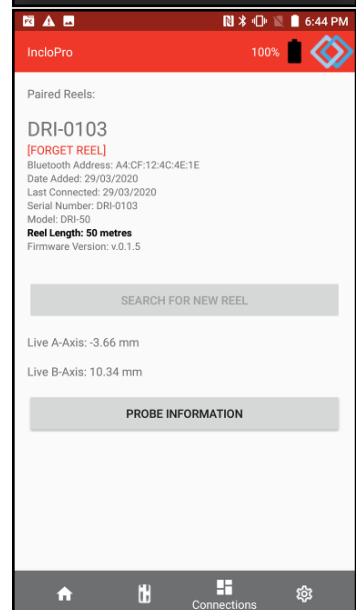
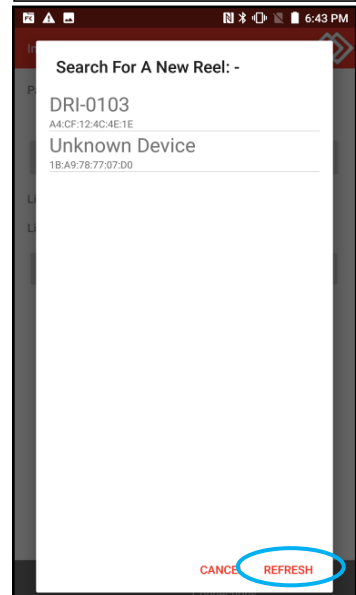
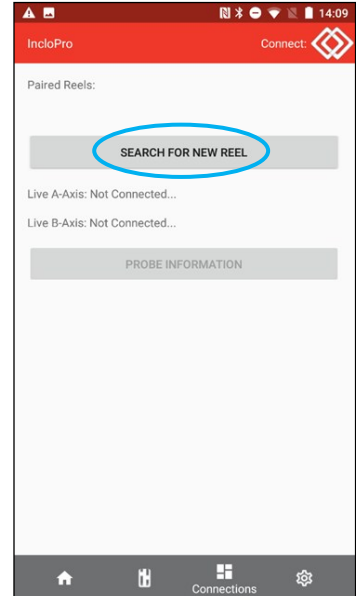

6.5.3. Setting up a Site

Tapping the Boreholes icon  will show the following screen:



If the ASD is connected to the probe, it is necessary to tap the connection icon  to disconnect Bluetooth at this stage.

Before a survey can be carried out, it is necessary to set up a Site and add a Borehole (any number of boreholes can be added to a single site).

Tap the add button  next to the site list, and the screen will change to 'Add a New Site'.

Enter a site name and tap **OK**.

More than one site can be created in the app. You can search for the sites you have added by using the site list drop-down arrow.

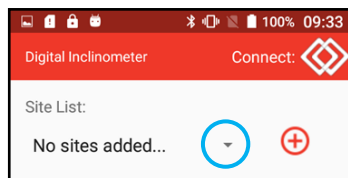
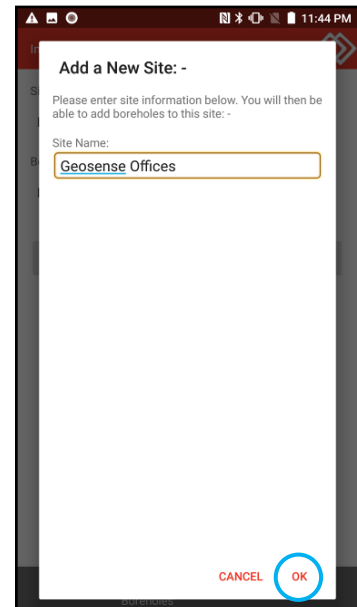
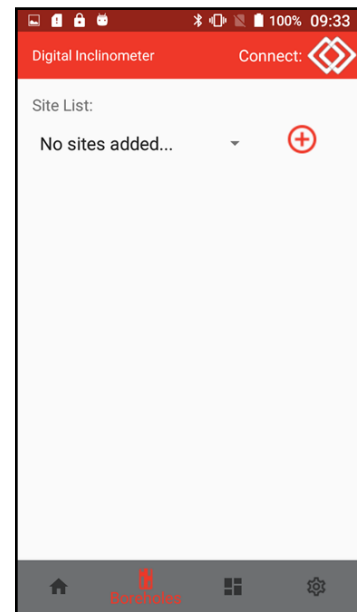

6.5.4. Adding a Borehole

Tap the add button next to the empty borehole list for the selected site, and the screen will change to 'Add a New Borehole'.

Now, enter a valid **Borehole Name**.

Select **Metric** (default) or **Imperial**.

This manual assumes a Metric Probe, but the functionality remains the same for the Imperial Probe.

Enter the **Depth** of the borehole. This is the depth of the deepest reading, **not the actual depth** (it may be necessary to lower the probe and cable down to the base of the inclinometer tubing and insert the cable support to determine this value; the probe MUST be suspended). **Once this value has been saved, it cannot be changed by editing** (the borehole would need to be deleted, and the information re-entered).

The **interval** defaults to 0.5m (a reading every 0.5m) as the standard **Geosense® Portable Inclinometer Probe** is 0.5m long. This can be changed to an interval of 1m if using a 1m long probe.

The graphing options default to use the base of the borehole as the fixed **Reference**. This can be changed if the base cannot be considered as 'fixed'. In this case, the **TOP** can be referenced, but a topographical survey will be required to measure any changes to the position of the top.

Up to 5 photos can be added to the memory of the ASD to help identify the borehole location. Tap **OK**, and the Borehole Screen will update to show the borehole information you have entered.

The following options become available:

TAKE READING

VIEW DATA

LOCATE BOREHOLE VIA GPS

Scrolling down the screen will reveal:

EDIT BOREHOLE

DELETEBOREHOLE

DELETE SITE

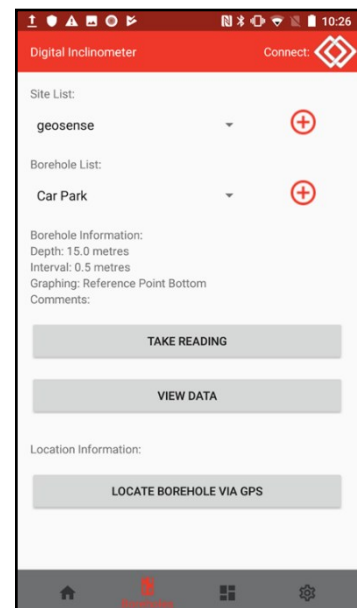
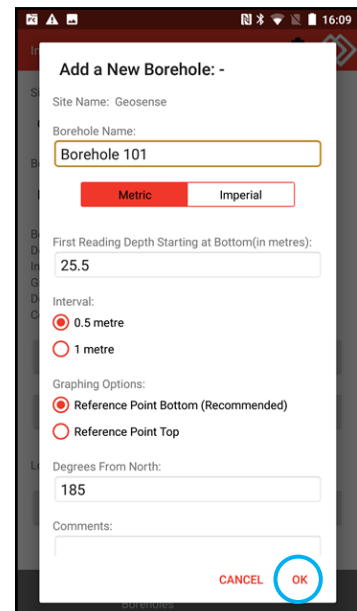
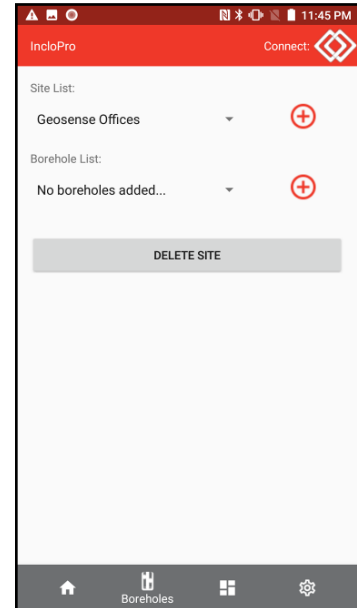

6.5.5. Settings

The Settings Screen allows the user to customise features within the app.

- Enable **Vibration** on 'Accept Reading'
- Enable **Tone** on 'Accept Reading'
- Remove 'Settling Time Screen' when taking a reading
- Default **operator name** for 'Save Survey'
- **Configure the number of stable readings** in 'Automode'. This controls how long the readings remain stable prior to the ASD automatically recording them and prompting the user to move the probe up to the next position.

Immediately (default):	as soon as it stabilises
5:	approx. 3 seconds additional
10:	approx. 6 seconds additional

- The 'Export File Format Type' allows the user to **select CSV or RPP file outputs when exporting data** (RPP output is compatible with Sitemaster and Inclinalysis).
- Set the **default email address** for survey data transmission.

Set **FTP settings** for survey data export. A test facility is also available for the FTP settings.

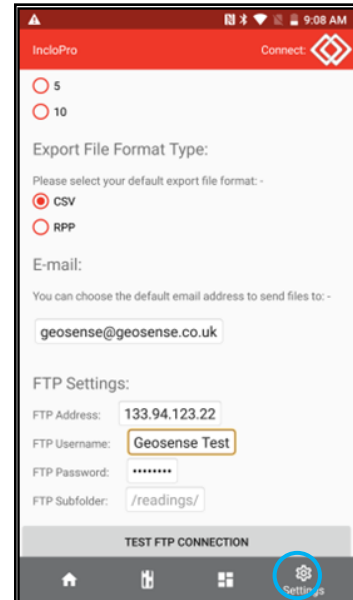
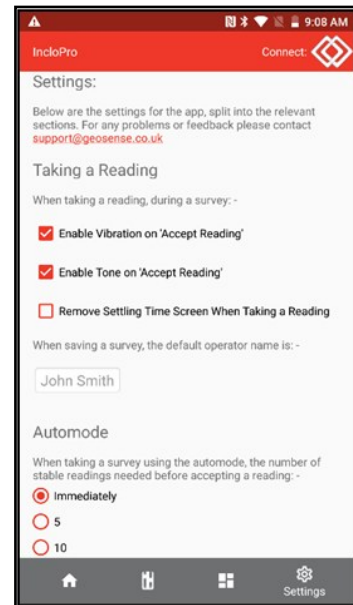

6.5.6. Taking Readings (also detailed in section 6.4)

Having set up the site and borehole, an inclinometer survey can be carried out.

If not already carried out, connect the probe and lower it to the base of the inclinometer tube. For the cable suspension. Ensure the reel is switched on and the correct site and borehole are selected.

From the Boreholes Screen, tap on the **'TAKE READING'** button.

The ASD will now automatically begin trying to connect to the reel and probe to retrieve the temperature readings and will display the Stabilisation Period Screen.

Note: In the event the application fails to connect to the reel, tap the connect icon  to re-establish a connection.

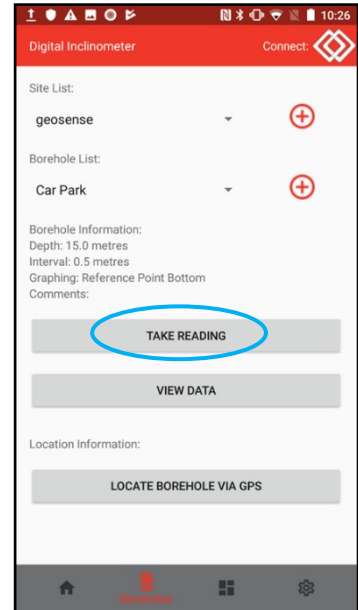

The screen illustrates how to position the probe in the A+ orientation in the casing. Having connected to and lowered the probe, temperature changes can be observed. The app monitors the temperature changes and indicates a red **'Probe Temperature Stabilising'** or a green **'Probe Temperature Stabilised'** to show when to begin the survey, assuring the most accurate readings. Depending on the conditions, thermal equalisation can require up to 10 minutes to complete.

*The Stabilisation Period Screen is an optional screen that can be skipped by tapping the **'SKIP- BEGIN SURVEY'** button. It can also be switched off entirely in the Settings Menu. The purpose of this screen is to allow the probe structure and its electronics to adjust to the temperature at the bottom of the borehole before taking readings, and it is **highly recommended** for more accurate readings*

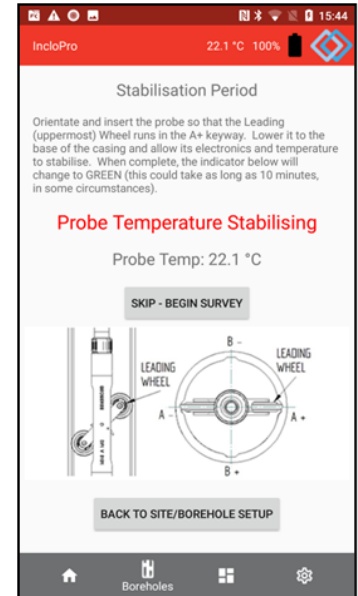

To begin a survey, tap **'BEGIN SURVEY'**.

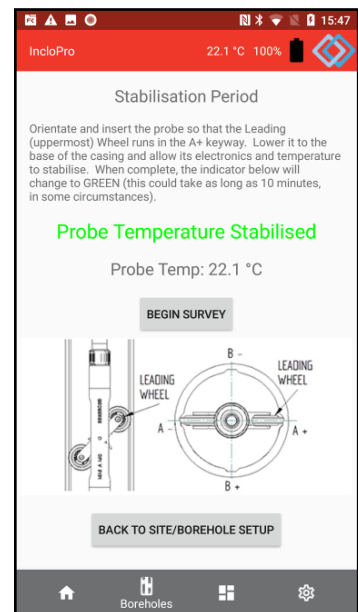

6.5.7. Taking Readings Screen

The readings begin with the leading wheel in the A+ keyway and with the probe suspended at the bottom of the borehole. Whilst connected to the Reed/Probe, live inclination readings are displayed on the screen on both the A and B axes, in mm. Each reading is approximately 0.6 seconds apart. The probe can measure an inclination angle up to 30°, which is approximately 250mm, on each axis. If the probe exceeds this maximum angle, the onscreen display will change to say 'OR', which means 'Over Range'.

The stability of the probe in the borehole can be measured using the red/green stability bar beneath the readings:

Green = Stable
Red = Unstable

This assessment uses the last 10 live readings and calculates the standard deviation across those readings to measure the difference. It is recommended to wait until the stability bar (and 'Accept Reading' button) shows green before accepting a reading, but this might not be possible if there are external vibrations near the borehole.

When the user taps 'ACCEPT READING', the reading at that depth will be recorded to the memory, and the ASD will produce a BEEP and/or VIBRATE. The indicated depth will change by the 'interval' to show the next depth (both vibration and a beep can be switched on/off in the Settings Menu).

Use the 'QUICK DATA CHECK' button to view the readings stored in memory so far, at any point in the survey (perhaps check the current position in the borehole survey). 'CANCEL' will return to the Take Readings Screen.

If an error is detected, the depth can be changed to retake a reading from another position by using the UP/DOWN buttons.

Continue the survey in the A+ direction.

When at 0.5m (the top of the borehole), tap 'ACCEPT READING' to record the last reading for that direction.

This will bring up the 'Switch Orientation?' Screen.

For a one-face survey, tap 'ONE FACE SURVEY'. This will bring up the Save Survey Screen to fill in the operator name and an optional comment to help identify the survey. Then tap 'OK'.

For a normal survey, remove the probe from the borehole and rotate it 180 degrees to the 'A-' orientation, using the diagram on screen for reference if needed. Then tap 'OK'.

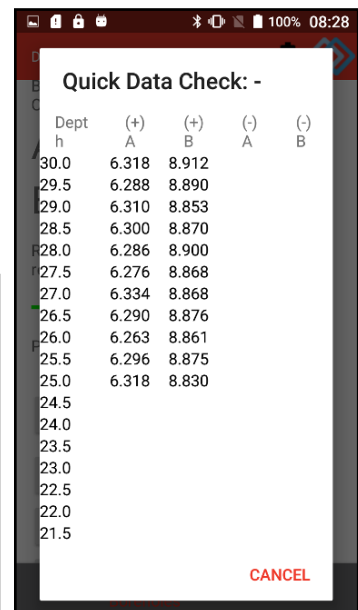
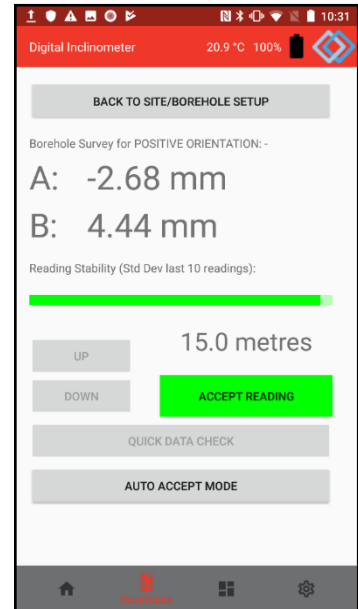
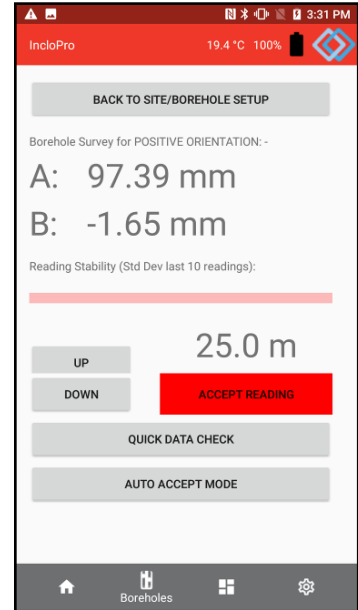
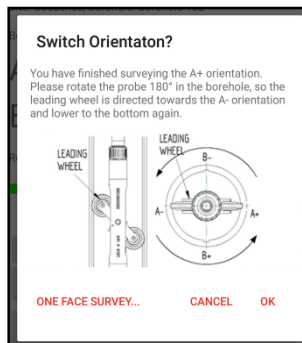

The screen will update to show 'NEGATIVE ORIENTATION' with live 'checksums' beneath each axis.

Continue the survey...

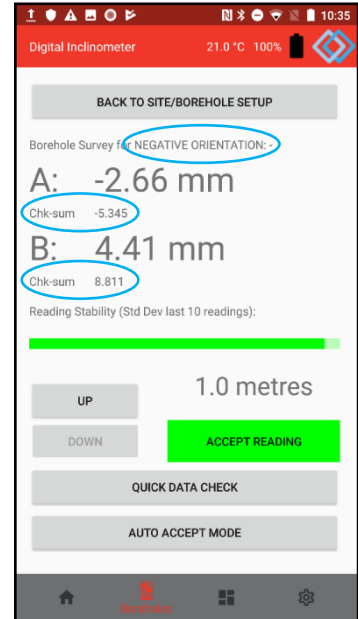

When the top is reached again, take the final reading by tapping 'ACCEPT READING'.

This will bring up the Save Survey Screen. Enter the operator name (unless this has been set as a default in Settings) and an optional comment to help identify the survey or site conditions. Tap 'OK'. Surveys are automatically saved with the date/time as their name to make identifying them easier.

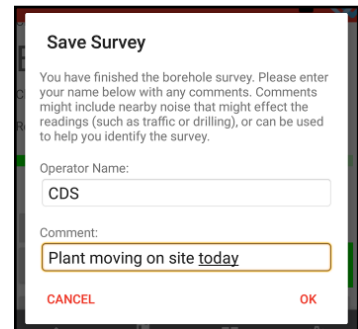

AUTO ACCEPT MODE

This mode has been incorporated into the **Geosense® Inclinometer Systems** to help provide reliable and repeatable data sets, together with simplification of the monitoring operations. It is also used to complete a survey as a 'hands-free' operation.

Once the monitoring of a particular inclinometer tube has been started, the operator selects 'AUTO ACCEPT MODE'.

Auto Accept Mode uses a probe stability monitor and a countdown timer to work out when to take a reading. It then instructs the user to move the probe after a reading is taken. The app will continuously beep to alert the user to move the probe to the next position – this beep **cannot** be turned off in settings (as it can in manual readings).

The number of stable readings required before a reading is taken in this mode can be configured in the Settings Menu within the app. The default is 1, but it is commonly set to 5.

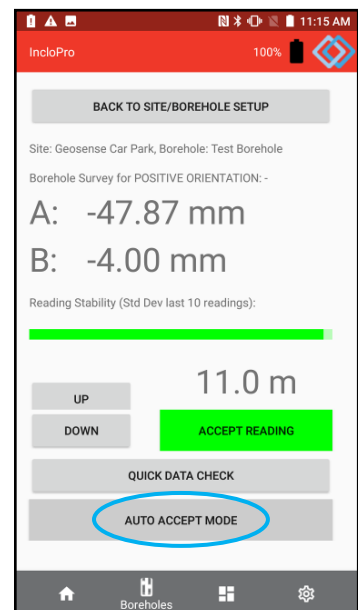

When 'AUTO ACCEPT MODE' is tapped, the screen changes to show the Auto Accept Window.

The Auto Accept Screen differs from the Manual Screen in that it has larger displays of key information since the ASD can be placed safely away from the borehole (but must remain within earshot and Bluetooth range).

When the probe is stable, the stabilisation counter (as defined in Settings) begins. After the countdown, the readings are automatically recorded.

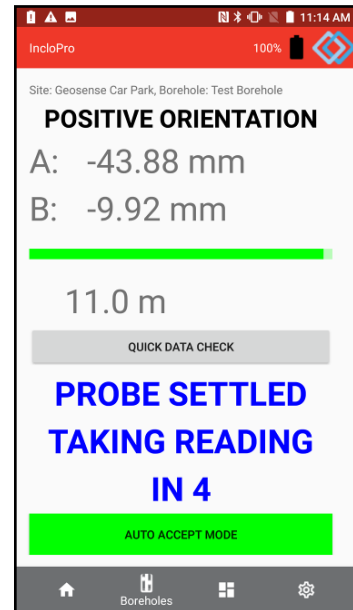

The display then changes the depth value to the next interval and prompts the user to move the probe and beeps loudly.

The beep will continue until the probe is moved to the next reading position.

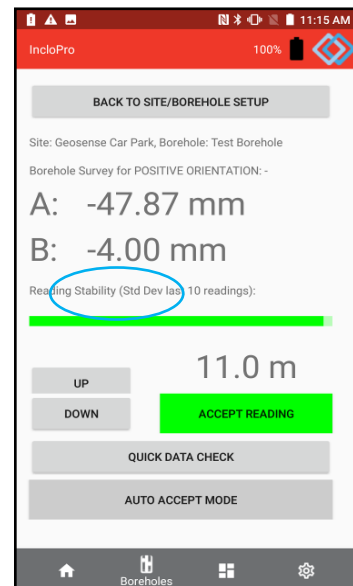

When the probe is moved, the beeping stops and the screen changes.

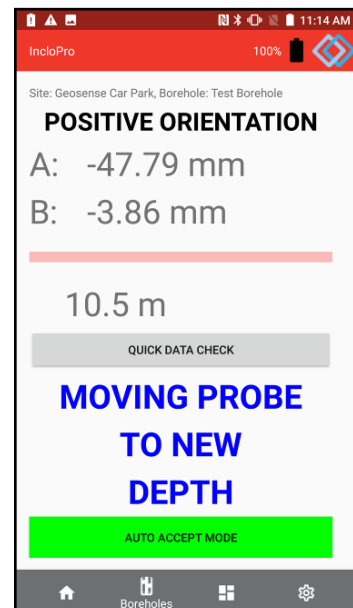

When the sensors detect the probe has been positioned at the next reading position, the screen changes as the readings stabilise.

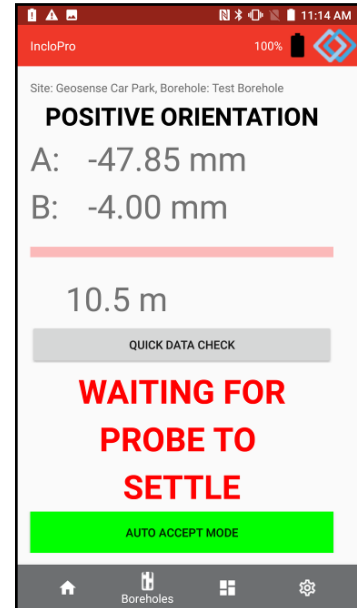

When the readings have stabilised, the Additional Readings counter is triggered again and displayed. The ASD waits for the set period as the counter decreases, then records the values.

At any time, the 'QUICK DATA CHECK' can be activated, but Auto Mode must be cancelled first.

If the probe stability remains **RED** for a continuous 60 seconds, the app will revert to Manual Mode as it deems the site/position to be subjected to too much vibration (noise).

Auto Accept Mode can be started or cancelled at any depth, even midway through a survey.

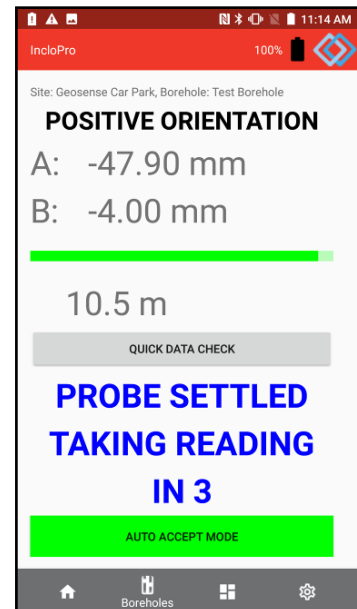

6.5.8. Viewing Data

All completed surveys can be accessed from the View Data Screen, located within the Borehole Selection Screen.

All completed surveys for a selected borehole are listed on this screen. Up to 3 surveys can be flagged as **'Base Readings'** using the **'Set Base Surveys'** button.

Listed surveys can be selected with the following options available for each:

- **Survey Data Table**
On-screen display of the survey data (for the survey selected at a time).
- **Upload Selected Survey to FTP**
Creates an output file (in the selected output format) and uses the FTP details entered in the Settings Menu to FTP the file for further analysis.
- **Email/Save to Phone/Bluetooth**
Creates an output file (in the selected output format) ready to be saved onto the phone or emailed. A default email address can be entered into the settings menu to speed up this process.
- **Checksum A/B Axis Graph**
On-screen graph showing checksum for each axis.
- **Absolute One-Face Graph**
Only available for one-face surveys.
- **Absolute Position A/B Axis Graph**
On-screen graph showing absolute position for each axis.
- **Mean Deviation A/B Axis Graph**
On-screen graph showing mean deviation for each axis.
- **Incremental Displacements A/B Axis Graph**
On-screen graph showing incremental displacement across each axis (requires at least 1 base survey to be flagged for calculations).
- **Cumulative Displacement A/B Axis Graph**
On-screen graph showing cumulative displacement across each axis (requires at least 1 base survey to be flagged for calculations).
- **Delete Selected Surveys**

The graphs are all fully zoomable and can be toggled to show datapoint information 'on' and 'off' by tapping the **'INFO'** button. Multiple surveys from the same borehole can be plotted on one graph (by selecting the surveys).

The graphs are plotted with the 0.0 depth of the borehole at the top to provide a representation of the borehole to help visualise changes.

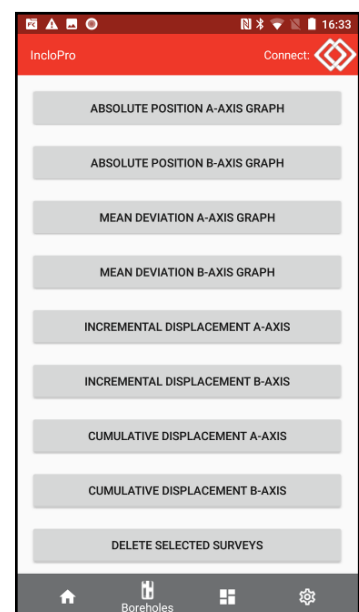
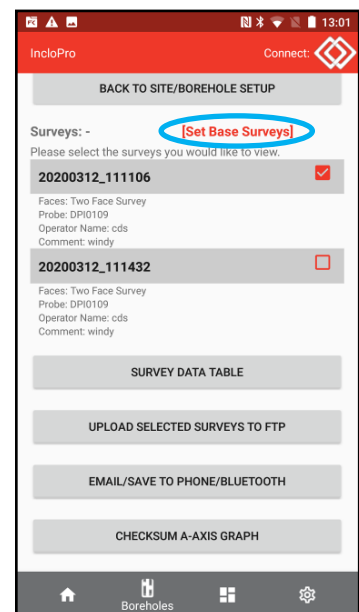
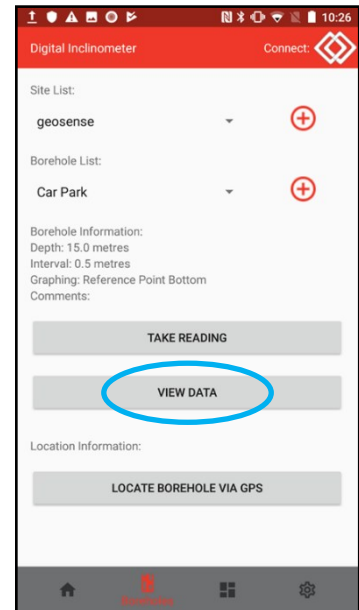

INITIAL/BASE DATA

It is common to carry out 3 sets of Initial Readings to form the Base Data File.

Therefore, **IncloPRO** can use 1, 2 or 3 sets of data to form the Base Data File, to which subsequent readings are compared. The app averages the readings at each depth, so it is important that only 'GOOD' data is used as the Base Data Reference.

Readings can be viewed and graphed to assess their quality and suitability for the Base Data File.

To select data set(s) for use as the Base Data, tap **[Set Base Surveys]** at the top of the Surveys List

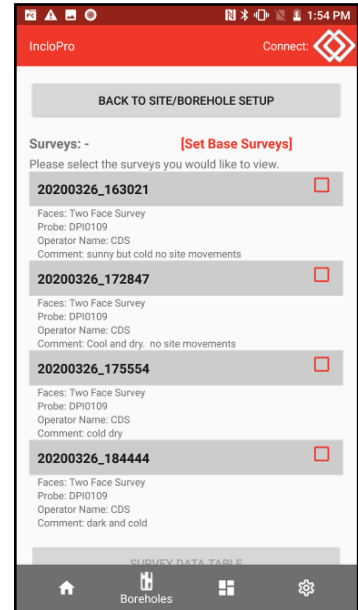

Select the suitable files and tap **OK**.

This selection is stored on the ASD so that it is not necessary to make this selection each time the data is viewed.

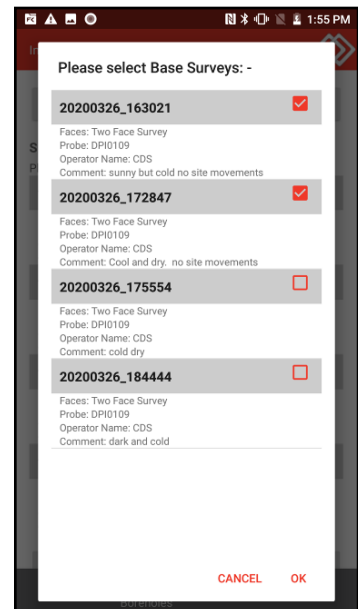

SURVEY DATA TABLE

Only one set of data can be viewed at a time, so to view the readings recorded for a particular data set, select only one file.

Tap the **SURVEY DATA TABLE** to view the readings in a tabular form.

Readings are displayed in columns showing Depth of the Reading, A+, B+, A-, and B-.

To return to the previous menu, tap **CANCEL**.

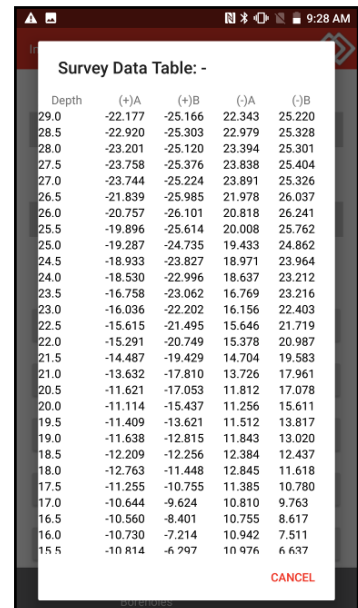

UPLOAD SELECTED SURVEY TO FTP

Where data is to be sent directly to a remote server, this option creates a file in the selected output format (CSV or RPP) and uses FTP details entered into the Settings Menu to effect the transmission. A mobile data connection (SIM card) or a WiFi network connection is required.

EMAIL/SAVE TO PHONE/BLUETOOTH

This option generates output files for each data set selected. The file name structure will be:

[site name]-[borehole name]-[date]_[time].csv

or

[site name]-[borehole name]-[date]_[time].rpp

The app asks where the file(s) are to be stored or sent. A mail client must be configured on the phone to send the data via email. A default email address can be entered into the Settings Menu to speed up this process.

First, select the files to be transferred, then tap the EMAIL/SAVE TO PHONE/Bluetooth option. This will bring up the transfer option window on the ASD.

To email the files, select the mail client and follow its procedures.

To save the File, select '**Save with FC**', which will lead to the save location window.

Select '**Internal Storage**' to save to a particular location on the device or '**Downloads**' to save directly to that location (other options are available).

To save the file(s) for later transfer by Bluetooth or USB cable, it's suggested that a folder be created in the 'root directory' in the internal storage of the ASD.

Tap to '**add folder**' icon  on the Folder Directory Screen to create a new directory, then select the new directory as the destination directory for the data files.

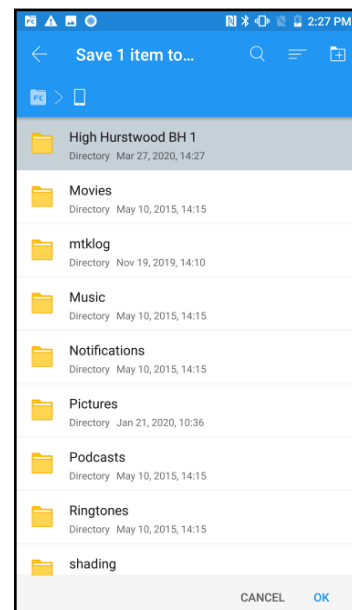
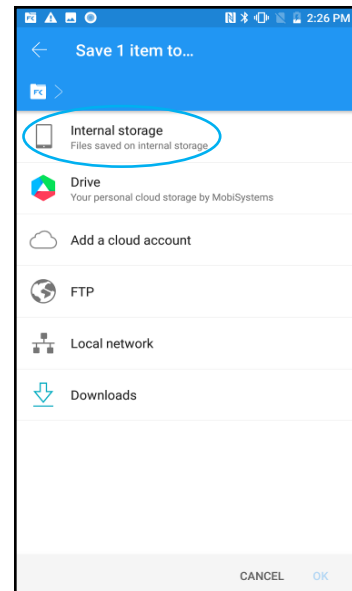
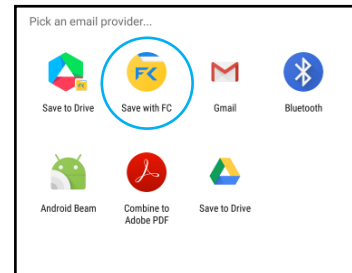

GRAPHS

Checksum A/B Axis Graph

On-screen graph showing checksum for each axis.

The checksum is a check on the quality and repeatability of the data.

Essentially, the 'scatter' of readings should be reasonably consistent, and the average of the line should be approximately vertical.

A drift in the verticality could indicate a thermal shift taking place during the reading process. This has an impact on the quality of the readings.

Horizontal spikes in the graph lines can indicate the following:

- A skipped or erroneous reading
- Defects/joints in the tubing
- An unstable reading

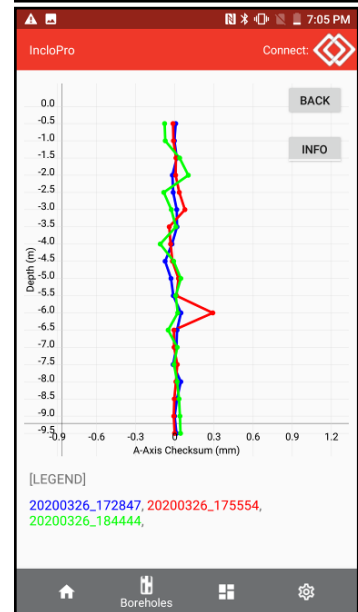
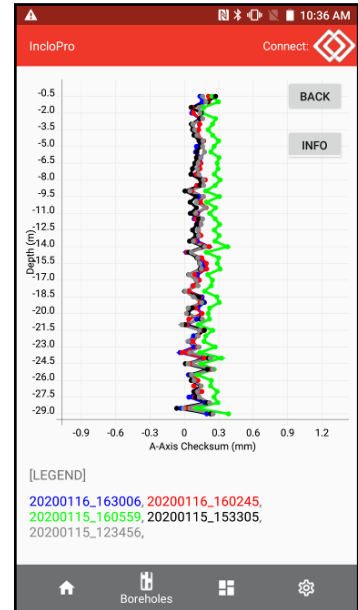

Absolute One-Face Graph

Only available for one face surveys (these are 'rough and ready' surveys to obtain approximate borehole alignments, so only rarely used).

Absolute Position A/B Axis Graph

On-screen graph showing absolute position for each axis.

This plot represents the true shape of the Inclinometer Tube with respect to Vertical, but to an exaggerated scale. The Y axis represents Vertical.

In this case, the base of the tube is only about 20mm from the top, in the A-direction.

This can be plotted for any/all data files, without the selection of a Base Data File.

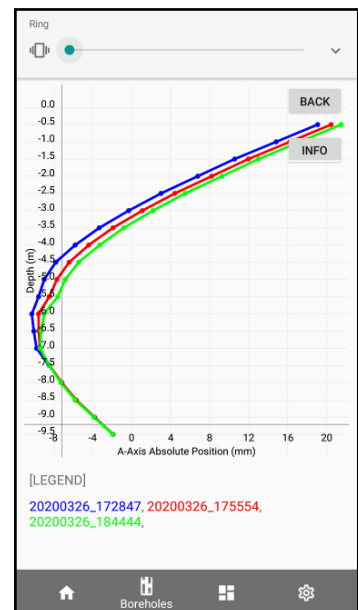

Mean Deviation A/B Axis Graph

On-screen graph showing mean deviation for each axis.

The deviation is the reading at EACH elevation, where the mean is the average of the A+ and A- readings (or B+ and B-).

This can be plotted for any/all data files without the selection of a Base Data File.

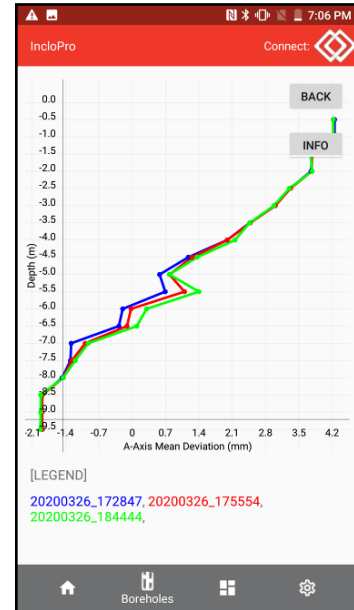

Incremental Displacement A/B Axis Graph

On-screen graph showing incremental displacement on each axis.

The Displacement is the difference between a previous reading and the current reading. It is necessary to select 1, 2 or 3 files (averaged) as the Base Data File(s) to which the subsequent data is compared and the difference calculated.

This graph shows the changes that have taken place at each individual reading position (NOT the change in the shape of the tubing).

The vertical Y axis represents the Base Data, and the plotted lines are the changes from the Base Data points.

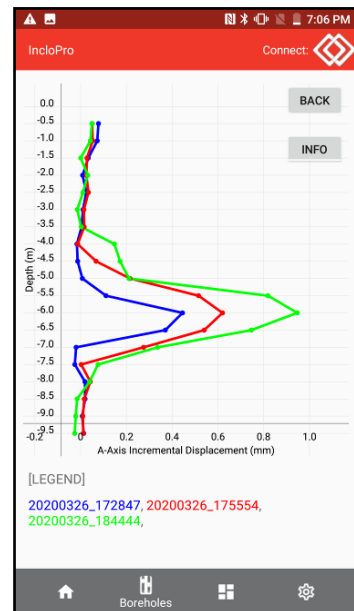

Cumulative Displacement A/B Axis Graph

On-screen graph showing cumulative displacement on each axis.

This displays the cumulative changes that have occurred and represents changes that have occurred and represents the changes in the shape of the tubing, to an exaggerated scale. Often, a succession of data files will show the progression of changes.

It is necessary to select 1, 2 or 3 files (averaged) as the Base Data File(s) to which the subsequent data are compared and the differences calculated.

The vertical Y axis represents the Base Data, and the plotted lines are the changes from the Base Data profile.

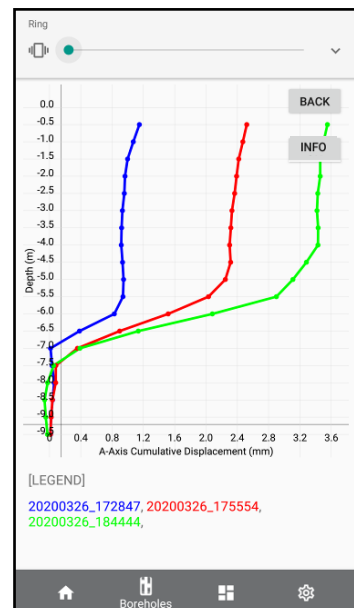

Graph Point Information

Data Point Information is available on any graph where the **INFO** button is displayed (top right corner of the Graph Screen).

Tap the **INFO** button to toggle on and off the data point information.



ZOOMING

All graphs are 'zoomable'. Use two fingers on the screen to zoom in or out for additional detail.

DELETE SELECTED SURVEYS

The surveys selected in the selection process will be deleted from the database within the ASD.

Any files created using the processes described in the 'file transfer routines' will not be deleted

LOCATION INFORMATION - Locate Borehole via GPS



Locating the borehole via GPS requires the phone to be signed in to the Google Play Store, at least a 3G SIM card connection and 'Location' turned on.

On the Borehole Screen, tap '**LOCATE BOREHOLE VIA GPS**'. When you are at the location of the borehole tap '**USE CURRENT LOCATION FOR BOREHOLE**' to store a location for the borehole. This can later be used to make locating the borehole easier (future surveys, perhaps carried out by different operators).

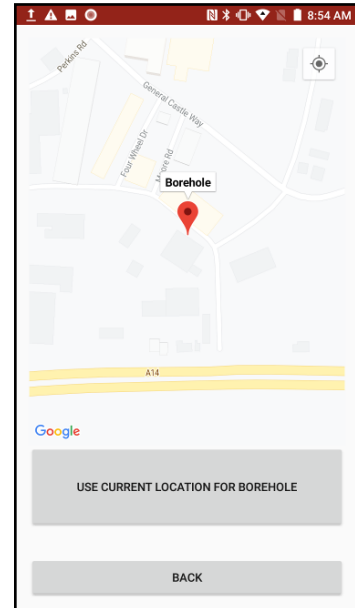

EDIT BOREHOLE

After a borehole has been added, the '**EDIT BOREHOLE**' button can be used to make changes to the borehole information.



Certain information, such as depth, interval and site name, cannot be changed.

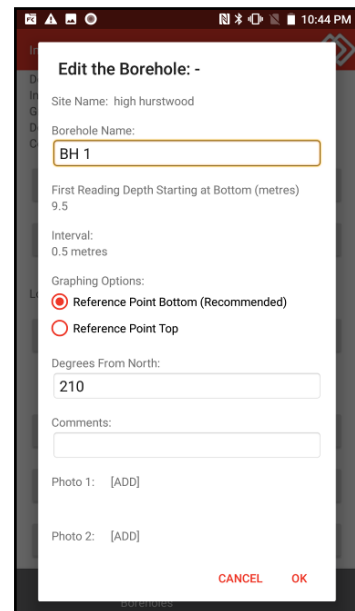

DELETE BOREHOLE

Select the borehole to be deleted and tap the '**DELETE BOREHOLE**' button.

The user will be asked to confirm this action. To do this tap **YES**.



This will also delete ALL surveys and readings for this borehole.

Any files created using the processes described in the 'file transfer routines' will not be deleted.

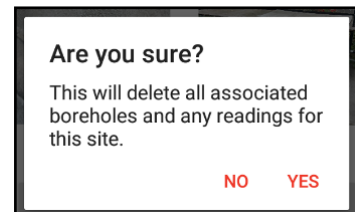

DELETE SITE

Select the site to be deleted and tap the '**DELETE SITE**' button.

The user will be asked to confirm this action by tapping **YES**.



This will also delete ALL boreholes, surveys and readings for this site.

Any files created using the processes described in the 'file transfer routines' will not be deleted.

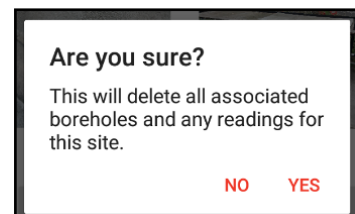

6.5.9. Data Transfer

To transfer data from the ASD to a PC using a USB cable, connect the USB cable to the base of the ASD and the PC.

Windows (or other OS) will search for the necessary communication drivers, and then it may indicate that the drivers were either successfully or unsuccessfully installed.

Either way, tap the **SETTINGS** icon on the ASD.

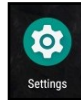

Select **Connected Devices**.

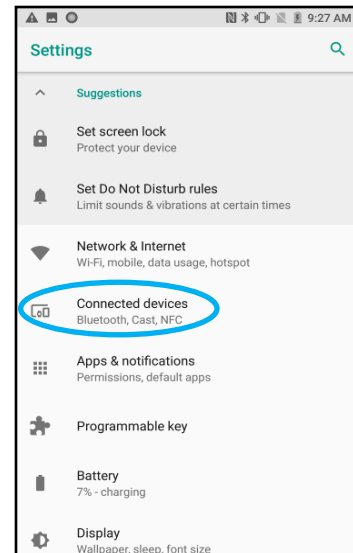

Select **USB**.

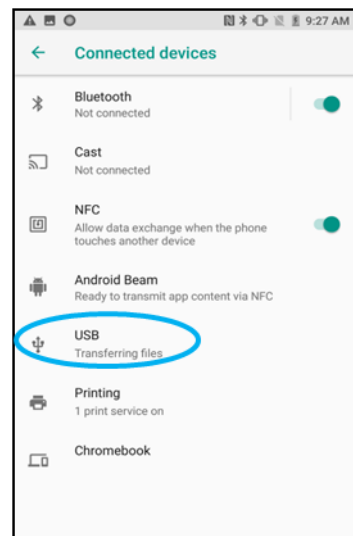

Select **Transfer files**.

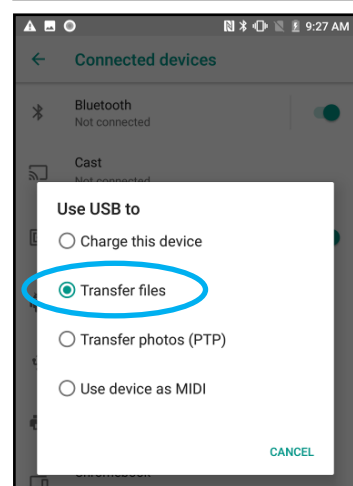

Windows should now acknowledge a change in the status of the connected device and open an **AutoPlay** window with the 'ASD name' as the device.

Select the '**Open device to view files**' option.

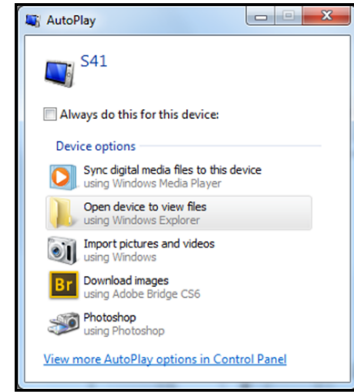

This will open an Explorer window to show the drive on the ASD.

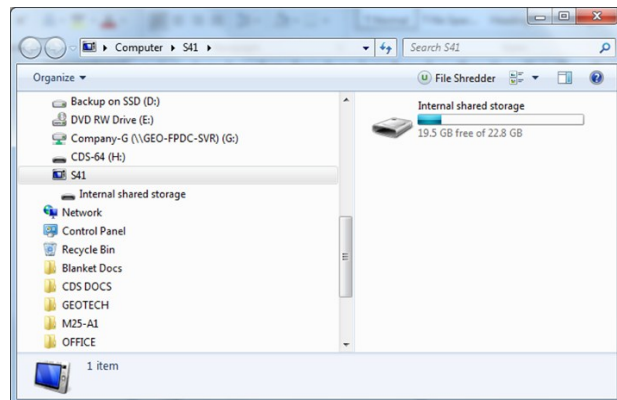

Open the '**Internal shared storage**' on the ASD.

Search for the data files or open the folder created to save data ready for Bluetooth or USB transfer.

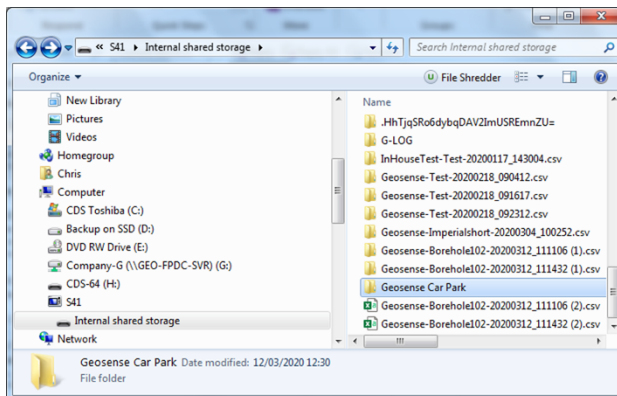

As an example, in this case, the data files are in the '**Geosense Car Park**' folder (highlighted).

Copy the required data files to the PC using **COPY** and **PASTE**.

The data files are in the '.csv' format and can be opened by most spreadsheet software packages and text editors.

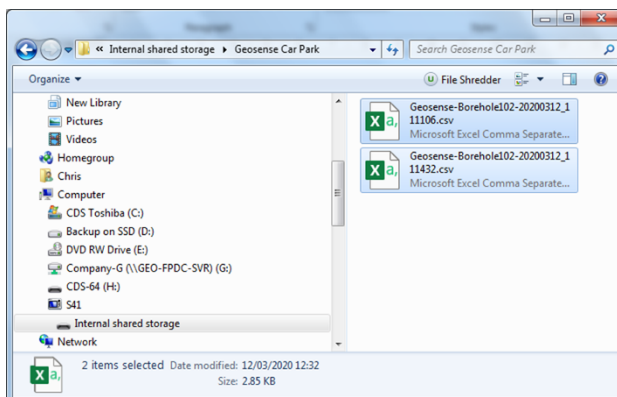

7. DATA HANDLING

7.1. Data Format

Once an inclinometer survey has been completed the readings are saved to the database on the ASD/ the data can be viewed on the ASD using the **IncloPRO** app, as describe in section 6.5.

For detailed analysis, either automated or manual, the recorded values need to be transferred to another device. However, the values in the database are not directly accessible so they must be 'shared' or 'exported'. A summary of the methods of transfer are provided in section 6.5.9.

If '.csv' format id selected, the exported data file format is ASCII, making it small in size and commonly accessible via many software packages.

Geosense® has worked closely with 'Deep Excavations Inc' to enable PC based data handling via their **Site Master** Inclinometer Data Presentation Software package. Data exported from the ASD can be simply and easily imported into **Site Master** for clear and effective computation and presentation. For details refer to **Geosense Limited**.

The structure of an exported file is detailed below. It comprises a header that includes details of the site, borehole, equipment, survey and operator, followed by strings of data. Below is an example of the information included in the header and its 'comma separated' layout (as opened in a Text Editor).

```
Site Name: Budleigh Salterton,,,,,,,,,,,,,,,,,,,,,,,,,,,,,
Borehole Name: BH 1,,,,,,,,,,,,,,,,,,,,,,,,,,,,,,,,,,,,,
Borehole Depth: 9.5 metres,,,,,,,,,,,,,,,,,,,,,,,,,,,,,
Interval: 0.5m,,,,,,,,,,,,,,,,,,,,,,,,,,,,,,,,,,,,,,,,,
Degrees From North: 210,,,,,,,,,,,,,,,,,,,,,,,,,,,,,
Latitude: 50.630998, Longitude: -3.320214,,,,,,,,,,,,,
Operator Name: CDS,,,,,,,,,,,,,,,,,,,,,,,,,,,,,,,,,,,,,
Probe Serial Number: DPI0109,,,,,,,,,,,,,,,,,,,,,
Reel Serial Number: 103,,,,,,,,,,,,,,,,,,,,,,,,,,,,,
Survey Date: 20200326_163021,,,,,,,,,,,,,,,,,,,,,
Survey Comment: sunny but cold no site movements,,,,,,,,,
```

Opened in a spreadsheet, each comma should be set to delineate a column so the header information would be presented as follows:

Site Name: Budleigh Salterton	
Borehole Name: BH 1	
Borehole Depth: 9.5 metres	
Interval: 0.5m	
Degrees From North: 210	
Latitude: 50.630998	Longitude: -3.320214
Operator Name: CDS	
Probe Serial Number: DPI0109	
Reel Serial Number: 103	
Survey Date: 20200326_163021	
Survey Comment: sunny but cold no site movements	

The above details are commonly entered manually at the setup stages, automatically when a survey is carried out or manually when a survey is saved.

The following line of the file identifies the sequence of the variable values in the subsequent lines. These 'column headers' are:

	A	B	C	D
1	Site Name: Budleigh Salterton			
2	Borehole Name: BH 1			
3	Borehole Depth: 9.5 metres			
4	Interval: 0.5m			
5	Degrees From North: 210			
6	Latitude: 50.630998	Longitude: -3.320214		
7	Operator Name: CDS			
8	Probe Serial Number: DPI0109			
9	Reel Serial Number: 103			
10	Survey Date: 20200326_163021			
11	Survey Comment: sunny but cold no site movements			
12	ID	DEPTH_METRES	A_POSITIVE_SINX	B_POSITIVE_SINX
13		19	0.5	0.0083666
14		18	1	0.0083852
15		17	1.5	0.0074967
16		16	2	0.0075014
17		15	2.5	0.0066257

- ID reading sequence (top of the tube = highest no.)
- DEPTH_METRES depth of a reading (cable marker value) in metres
- A_POSITIVE_SINX Sine of Angle of probe inclination for A+
- B_POSITIVE_SINX Sine of Angle of probe inclination for B+
- A_POSITIVE_MM Probe inclination in mm for A+ (mm per probe length)
- B_POSITIVE_MM Probe inclination in mm for B+ (mm per probe length)
- A_NEGATIVE_SINX Sine of Angle of prove inclination for A-
- B_NEGATIVE_SINX Sine of Angle of prove inclination for B-
- A_NEGATIVE_MM Probe inclination in mm for A- (mm per probe length)
- B_NEGATIVE_MM Probe inclination in mm for B- (mm per probe length)
- POSTIVE_TEMP Temperature of the probe electronics for the '+' readings
- NEGATIVE_TEMP Temperature of the probe electronics for the '-' readings

Below is a section of the transmitted '.csv' file as it would appear when opened in a Text Editor, showing only 'column headers' and the data values section of the file.

```
ID, DEPTH_METRES, A_POSITIVE_SINX, B_POSITIVE_SINX, A_POSITIVE_MM, B_POSITIVE_MM, etc
19,0.5,0.0083666,0.0019453,4.1833,0.97265,-0.0083284,0.0216397,-4.1642,10.8198, 17.246,17,532
18,1,0.0083852,0.0019631,4.1926,0.98155,-0.0083313,0.021654,-4.16565,10.827,17.253,17.545
17,1.5,0.0074967,0.0019666,3.74835,0.9833,-0.0074857,0.0215836,-3.74285,10.7918,17.251,17.538
16,2,0.0075014,0.0019636,3.7507,0.9818,-0.0074974,0.0215763,-3.7487,10.7881,17.260,17.545
etc, etc, etc
```

7.2. Data Reduction

Data reduction and presentation can also be carried out using a standard spreadsheet. The following is a guide on how each value would be calculated.

The first stage is to import the '.csv' data file, ensuring that a comma is identified as the 'delineator' for the columns.

Once the data is imported, and assuming that the site name is in cell A1, expand the columns to show all the values they contain.

	A	B	E	F	I	J
1	Site Name: Budleigh Salterton					
2	Borehole Name: BH 1					
3	Borehole Depth: 9.5 metres					
4	Interval: 0.5m					
5	Degrees From North: 210					
6	Latitude: 50.630998	Longitude: -3.320214				
7	Operator Name: CDS					
8	Probe Serial Number: DPI0109					
9	Reel Serial Number: 103					
10	Survey Date: 20200326_163021					
11	Survey Comment: sunny but cold					
ID	DEPTH_METRES	A_POSITIVE_MM	B_POSITIVE_MM	A_NEGATIVE_MM	B_NEGATIVE_MM	
13	19	0.5	4.1833	0.97265	-4.1642	10.8198
14	18	1	4.1926	0.98155	-4.16565	10.827
15	17	1.5	3.74835	0.9833	-3.74285	10.7918
16	16	2	3.7507	0.9818	-3.7487	10.7881
17	15	2.5	3.31285	1.01945	-3.26705	10.7821
18	14	3	2.97485	1.0234	-3.01115	10.775
19	13	3.5	2.4673	1.0566	-2.46255	10.7358
20	12	4	1.99455	1.04885	-2.0264	10.7139

To simplify the spreadsheet, it is recommended to hide all the columns EXCEPT **A, B, E, F, I** and **J**. therefore, the only visible columns will be the **Header Data** and **Column ID**, together with **Depth** and Readings for **A+, B+, A-** and **B-**.

The 0.5m reading for the A+ direction should be in cell **E13**.

Since inclinometer are commonly installed to quantify changes in a structure, it is necessary to establish the reference set of data to which subsequent data can be compared. The reference data set is often called the Base (or Initial) Data.

Commonly accepted 'Best Practice' is to record 3 sets of data from an inclinometer tube, soon after installation, to generate the Base Data. These should be recorded, one after the other, in the same conditions to verify the precise profile of the installed inclinometer tube. Following a review of the recorded files, either a single file can be selected as the 'Base Data File', being the mean of the sets, or an average data set can be created from 2 or all 3 of the surveys.

Commonly computed values include:

Mean Deviation

These values are actual inclinations of the probe, in mm, at each elevation (where Deviation implies offset from Vertical over the length of the probe wheelbase). For any particular depth, the values are calculated by the following equations:

$$\text{Mean A} = ((\text{Reading A+}) - (\text{Reading A-}))/2$$

$$\text{Mean B} = ((\text{Reading B+}) - (\text{Reading B-}))/2$$

Checksum

The checksums are a measure of the integrity of the data set. They compare the '+' and '-' values at each depth and compute the difference. The difference represents slight misalignments and imbalances in the electronics and mechanics of the probe. These are quite normal and the reason for recording both '+' and '-' values is to remove these differences. **Geosense®** calculate the Checksums using the follow equations:

$$\begin{aligned}\text{Checksum A} &= (\text{Reading A+}) + (\text{Reading A-}) \\ \text{Checksum B} &= (\text{Reading B+}) + (\text{Reading B-})\end{aligned}$$

Checksums should be reasonably small and consistent over the length of the survey.

Absolute

When plotted these values represent the actual shape of the inclinometer tube and provide an understanding of the verticality and any 'wander' of the installation. Computation for both the A and B directions will confirm the location of the base of the tube with respect to the top.

To calculate the absolute position values for the A direction, use the Mean A readings at each depth and starting at one end, add one to the next. This can be started from the top or the bottom of the survey, depending on the information required. The position of the tube at a particular depth is represented by the accumulation of the Deviations at that depth.

To calculate the total deviation from top to bottom, use the following equation:

$$\text{Tot. Dev.} = (\text{MD A@0.5} + \text{MD A@1.0} + \text{MD A@1.5} \dots + \text{MD A@Btm.})$$

Ditto for B

Incremental Displacement

This refers to CHANGES in the inclination of the tube at any particular depth. To calculate the Incremental Displacement, it is necessary to compare the Mean Deviation (Current Data) values with the Mean Deviation (Base Data) values.

The incremental Displacement at any depth is calculated using the following equation (where '0.5' is the selected depth).

$$\text{Inc Disp}(0.5\text{m}) = \text{MDev}(0.5) - \text{Mdev}(\text{Base})(0.5)$$

Cumulative Displacement

These values are probably the most valuable in any monitoring exercise. They are simply the accumulation of the CHANGES, normally from the base of the tube, up to the top, that represents MOVEMENT of the tube along its length.

To calculate the Cumulative Displacement values simply add the Incremental Displacement at the Base of the Borehole to Incremental Displacement at the next depth upwards and continue to the top.

When plotted with Zero at the base of the graph, the 'Y' axis represents the Base Data File, and the plotted values indicate the magnitude of the changes (profile of change).

7.3. Temperature Considerations

Geosense® has carried out significant research into temperature effects on the Probe and its electronics and has found that the thermal effects are very small. However, at the beginning of a survey it is strongly recommended that the temperatures in the probe be allowed to 'normalise' (referred to as the stabilising period), thereby removing temperature gradients within the MEMS circuitry.

Where the probe is used in an inclinometer access tube in a borehole or other subsurface structure, there is usually little variation in temperature over the length of borehole, so thermal effects will be small, and corrections will not be necessary.

However, if the probe is subject to rapid temperature changes, the readings may be affected. Thermal influences are complex. The effect of temperature changes on the MEMS sensor are generally insignificant, but this relates purely to the 'sensor' on the circuit board, inside the probe. Effects on the body of the probe, together with the structure into (onto) which the tubing is installed, will be very complex and difficult to quantify. Consequently, reliable compensation for such changes would be unreliable, so are not considered of value.

8. MAINTENANCE

The **Geosense® MEMS Digital Inclinometer** is a low maintenance device. With careful use, routine inspections and a small amount of maintenance, it will provide reliable data over a long period.

Upon completion of a monitoring exercise, it is strongly recommended that the probe and cable be wiped down to remove moisture and detritus. The connector caps should be fitted whenever the connector is separated. Do not store a wet cloth with the probe in the hard case. Connectors should always be dry and free from dirt before being stored for any periods, as trapped moisture may cause corrosion.

The probe wheels include sealed bearings so cannot be lubricated. However, the wheel carriage spindles should be occasionally lubricated with a light machine oil, to maintain free movement and reduce wear.

The cable connector includes a double O-ring sealing system. The O-rings should be wiped clean and lubricated with a small amount of Silicon Grease to maintain ease of connection. Contact **Geosense®** for information on how to service the connectors should they become dirty. A dirty connection will impede the function of the system, it is important the keep all connectors clean and free from debris at all times.

Batteries in the Reel and the ASD should be charged regularly to prevent deterioration and maintain their capacity. Only approved chargers should be used.

General Inspections should include the following:

Probe Wheels:	Do they move freely and is there any wear in the bearings?
Probe Wheel Carriages:	Do they move freely?
Probe Connector:	Is the connector clean, free from detritus? Are the pins straight and clear? Are the seals in good condition and lightly lubricated with silicon grease?
ASD:	Is it dry and are the ports clear of foreign materials?
Cable:	Is the cable twist and 'kink' free? Are there cuts or gouges in the sleeve?

STORAGE

Ensure all equipment is clean and dry. Store all equipment in dry cases, in a dry location (dry the cloth prior to storing it in the case). The cable connectors should be dried, and caps fitted.

9. TROUBLESHOOTING

Some common problems and their solutions are outlined below.

Fault	Possible Cause	Remedy
PROBE		
Difficulty in connection cable	Lack of lubrication	Lubricate with silicon grease only
Wheel set does not return to fully extended position:	Presence of dirt Lack of lubrication	Clean Lubricate wheel bearings with light machine oil If system persists, replace wheel sets*
Wheels do not turn freely	Presence of dirt Lack of lubrication	Clean Lubricate wheel bearings with light machine oil
REEL & CABLE		
Reel will not turn on	Flat battery Fault with battery	Charge battery Replace battery pack
Cable becomes kinked/twisted	Allowing probe to freefall and stopping abruptly	Replace cable Do not allow probe to freefall
ASD READOUT		
ASD will not turn on	Flat battery Fault with battery	Charge battery Replace battery
The ASD cannot find the reel	Reel not turned on	Turn on the reel
The ASD cannot connect with the reel	Bluetooth fault	Return to Geosense® for investigation
Bluetooth fails to connect	Incorrect connection sequence	ALWAYS use the App to connect the ASD to the Reel, NOT the phone software
Bluetooth fails to connect despite using App	Bluetooth fault	Return to Geosense® for investigation
The display freezes after extended periods of use	Bluetooth connection	Re-set the Reel (turn it off and on again) and re-connect using the APP to continue the monitoring
Fluctuating readings	Faulty signal from probe Site conditions	Check probe connection Check cable for damage Check Bluetooth connection Check ASD Change from AUTO to MANUAL mode to record best data

*If wheelsets are replaced the probe should be re-calibrated

10. SPARE PARTS

Under normal use spare parts are not generally required for **Geosense® Inclinometer Systems**.

However, the following items are available. It is strongly recommended that replacement service components be fitted by **Geosense®** or their qualified representatives:

- Wheel and Carriage sets, including pins and springs
- Batteries and Chargers – Reel & ASD
- Cable support
- Connector caps

Contact **Geosense®** for more details and Service/Calibration options.

11. RETURN OF GOODS

11.1. Returns Procedure

Geosense products are built to the highest quality and workmanship; however, if the goods need to be returned for either service/repair or warranty, the customer will need to submit a returns request on our website:

www.geosense.com/returns/

Once you have completed and submitted the online form, you will receive a RAN number, and a PDF copy of the form will be emailed to the provided email address and to our support team.

Please send the product back to the following address with the RAN number written on the side of the box.

Geosense Limited

Nova House
Rougham Industrial Estate
Rougham
Bury St Edmunds
Suffolk, England
IP30 9ND

Return delivery is payable by the customer, as are all inspection charges until a time as a warranty claim has been accepted at which point inspection charges will be credited.

11.1.1. Chargeable Service or Repairs

Inspections & Estimate

It is the policy of **Geosense®** that an estimate is provided to the customer prior to any repair being carried out. A set fee for inspecting the equipment and providing an estimate is also chargeable.

11.1.2. Warranty Claim

(see Limited Warranty Conditions)

This covers defects that arise as a result of a failure in design or manufacturing. It is a condition of the warranty that the **MEMS Digital Inclinometer** must be handled and used in accordance with the manufacturer's instructions and has not been subjected to misuse.

In order to make a warranty claim, contact **Geosense®** and request a **Returned Equipment Report Form (QF034)**. Tick the warranty claim box and return the form with the goods as detailed above. You will then be contacted and informed whether your warranty claim has been validated.

11.2. Packaging and Carriage

All used goods shipped to the factory **must** be sealed inside a clean plastic bag and packed in a suitable carton. If the original packaging is not available, **Geosense®** should be contacted for advice. **Geosense®** will not be responsible for damage resulting from inadequate returns packaging or contamination under any circumstances.

11.3. Transport & Storage

All goods should be adequately packaged to prevent damage in transit or intermediate storage.

12. LIMITED WARRANTY

The manufacturer, **Geosense Ltd.**, warrants the **MEMS Digital Portable Inclinometer** manufactured by it, under normal use and service, to be free from defects in material and workmanship under the following terms and conditions:

Sufficient site data has been provided to **Geosense®** by the purchaser as regards to the nature of the installation to allow **Geosense®** to select the correct type and range of **MEMS Digital Inclinometer** and other component parts.

The **MEMS Digital Portable Inclinometer** equipment shall be installed in accordance with the manufacturer's recommendations.

The equipment is warranted for 2 years from the date of shipment from the manufacturer to the purchaser.

The warranty is limited to the replacement of part or parts that are determined to be defective upon inspection at the factory. Shipment of defective part or parts to the factory shall be at the expense of the Purchaser. Return shipment of repaired/replaced part or parts covered by this warranty shall be at the expense of the Manufacturer.

Unauthorised alteration and/or repair by anyone, which causes failure of the unit or associated components, will void this **LIMITED WARRANTY** in its entirety.

The Purchaser warrants, through the purchase of the MEMS Digital Inclinometer equipment, that he is familiar with the equipment and its proper use. In no event shall the manufacturer be liable for any injury, loss or damage, direct or consequential, special, incidental, indirect or punitive, arising out of the use of or inability to use the equipment sold to the Purchaser by the Manufacturer.

The Purchaser assumes all risks and liability whatsoever in connection with the **MEMS Digital Portable Inclinometer** equipment from the time of delivery to the Purchaser.



HEAD OFFICE

Nova House
Rougham Industrial Estate
Rougham, Bury St Edmunds
Suffolk, IP30 9ND
England

+44 (0)1359 270457
sales@geosense.com
support@geosense.com

NORTH AMERICA OFFICE

15 West 38th Street
Suite 632
New York
NY 10018

+1 518-920-3483
sales@geosense.com
support@geosense.com

www.geosense.com