

MEMS TILT BEAM

DIGITAL

I
N
S
T
R
U
C
T
I
O
N

M
A
N
U
A
L



CONTENTS

		Page
1.0	INTRODUCTION	4
1.1	General description	4
1.2	Electro magnetic compatibility	5
1.3	Effects of temperature	5
1.3	Theory of operation	6
2.0	CONFORMITY	7
3.0	MARKINGS	8
4.0	DELIVERY	9
4.1	Packaging	9
4.2	Handling	9
4.3	Inspection	9
4.4	Storage	10
5.0	INSTALLATION & ELECTRICAL CONNECTION	11
5.1	Preliminary considerations	11
5.1.1	Tools & Consumables	12
5.1.2	Cables & connections	12
5.1.3	Readout connection	13
5.1.4	Wireless connections	13
5.1.5	Data logger connection	13
5.1.5	Functionality testing	13
5.2	Installation Procedures - introduction	14
5.2.1	Markings/orientation	14
5.2.1.1	Horizontal beam marking	14
5.2.1.2	Vertical beam marking	15
5.3	Anchor/fixing installation	16
5.3.1	Through bolts	16
5.3.2	Resin bonded groutable anchor	17
5.4	Horizontal installation (vertical mount)	19
5.5	Horizontal installation (horizontal mount)	22
5.6	Vertical installation	23
5.7	Electrical connections	26
5.7.1	Extension cable	26
6.0	READOUTS	27
6.1	Digital interface	27
6.2	WI-SOS 480 Digital Node	27
6.3	Windows Tablet/PC	28
6.4	Data loggers	29

CONTENTS contd..

		Page
7.0	DATA HANDLING	30
7.1	Direction convention	30
7.2	Taking readings	31
7.2.1	Tilt Beam commands format	31
7.2.2	Tilt Beam commands	31
7.2.3	Tilt Beam error messages	31
7.2.4	G-Tilt software - quick guide	32
7.2.5	Tilt Checker software	34
7.3	Data conversion	35
7.4	Temperature effects	36
8.0	MAINTENANCE	37
9.0	TROUBLESHOOTING	37
10.0	SPECIFICATION	39
11.0	SPARE PARTS	40
12.0	RETURN OF GOODS	40
13.0	LIMITED WARRANTY	41

1.0 INTRODUCTION

This manual is intended for all users of the **Geosense® MEMS Digital Tilt Beams** and provides a guide for its installation, operation and maintenance.



It is VITAL that personnel responsible for the installation and use of the MEMS Tilt Beam READ and UNDERSTAND the manual, prior to working with the equipment.



1.1 General Description

The **Geosense® MEMS Digital Tilt Beam** comprises of a single tilt sensor mounted in an environmentally sealed aluminium module fixed to a Glass Reinforced Plastic (GRP) beam. The beam is mounted onto a surface to register changes in the tilt (rotation) across the length of the beam. Commonly these Tilt Beams are used for monitoring structural elements within civil engineering, but they are suitable for many other applications where the measurement of tilt is required.

A **Geosense® MEMS Digital Tilt Beam** can be installed or included in many types of monitoring regime and can be linked to various types of readout equipment.

The primary use for **Geosense® MEMS Digital Tilt Beams** is for the measurement of tilt of structures and retaining walls.

Examples of other applications are:-

- Monitoring of compensation grouting works.
- Effects of construction e.g. tunnelling or excavations on adjacent structures.
- Analysis of the performance of bridges, beams and dams under loading.
- Structural safety monitoring in areas of mass movement.
- Monitoring of retaining wall rotation.
- Convergence monitoring within tunnels (in association with other sensors).

Particular features of the **Geosense® MEMS Digital Tilt Beam** are:-

- Reliable long term performance.
- Suitably rugged for use in demanding environments.
- High accuracy and repeatability
- Designed to be resistant to EMF
- Suitable for long cable lengths or RF data transmission
- Digital units can be 'bussed' to form a chain of sensors.

Geosense® MEMS Digital Tilt Beam sensors are particularly suitable for the demanding environments of civil engineering projects since the signals are capable of long transmission distances (around 1000m), without degradation. They are also **water resistant** and can be shielded from interference from external electrical noise.



1.2 EMC - Electro Magnetic Compatibility

EMC is the electromagnetic interaction of electrical and electronic equipment with other electrical and electronic equipment. All electronic devices have the potential to emit and be affected by electromagnetic fields. With the reduction in size of electrical components and the ever increasing amount of electrical & electronic devices such as mobile phones, two-way radios, safety control systems, signalling, generators, welding equipment, power cables etc in all environments, especially construction sites, there is a huge potential for devices to interfere with each other.

Geosense® MEMS Digital Tilt Beams have been designed and tested for EMC under the relevant CE marking directives to comply with the highest standards including requirements set out in London Underground requirements G-222 & 1-222. This ensures correct operation under the harshest of site conditions.

However to ensure compliance and correct operation it is vital that all cables connected to **Geosense® MEMS Digital Tilt Beams** provide adequate 360 degree screening against EMC and that suitable EMC glands are used for any connection to junction boxes or data logger cabinet. However, as it is likely that **Geosense® MEMS Digital Tilt Beams** will be used in conjunction with data loggers, it is essential that they too are designed and constructed to comply with the relevant CE marking directives (contact Geosense for details).



FAILURE TO PROVIDE SUITABLY SCREENED CABLES & ENCLOSURES, TOGETHER WITH EMC GLANDS COULD RESULT IN OPERATIONAL FAILURES WITHIN THE EQUIPMENT



1.3 The Effects of Temperature Changes

The MEMS sensors used in the **Geosense® MEMS Digital Tilt Beams** offer significant advantages over other types of rotational movement sensors, with respect to thermal stability. The sensors themselves are almost unaffected by environmental temperature changes.

However, whilst efforts have been taken to minimise the effects, the instrument mountings and the enclosure will be affected by significant temperature changes, along with the structure onto which the instrument is fixed. Effects will be highest when the temperature changes are large and over a short period of time.

For this reason, **Geosense® MEMS Digital Tilt Beams** include a Temperature measurement facility (Thermistor) to help identify the in-situ effects of any thermal changes.

1.4 Theory of Operation

Geosense® MEMS Digital Tilt Beams employ 'State of the Art' MEMS sensor technology. MEMS (Micro - Electro - Mechanical Systems) are an integration of mechanical elements, sensors, actuators and electronics on a common silicon substrate through micro fabrication technology.

The mechanical structure of a typical MEMS sensor is shown in Figures 1 & 2 below.

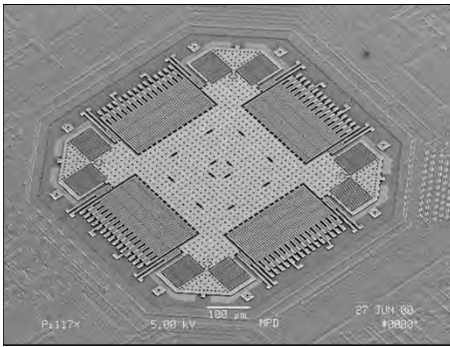

Figure 1

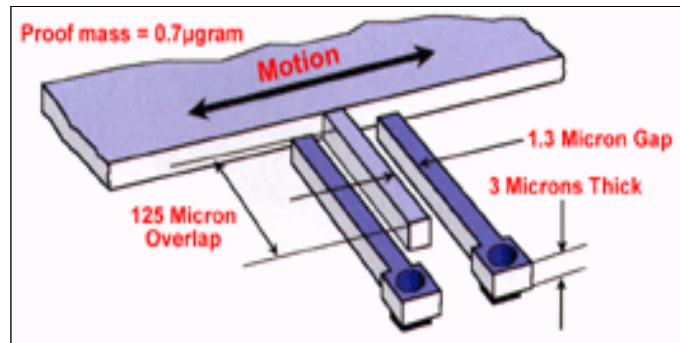

Figure 2

Polysilicon springs suspend the MEMS structure above the substrate such that the body of the sensor (also known as the 'proof mass') can move in the X and Y axes. Acceleration causes deflection of the proof mass from its centre position. Around the four sides of the square proof mass are 32 sets of radial fingers.

These fingers are positioned between plates that are fixed to the substrate. Each finger and pair of fixed plates make up a differential capacitor, and the deflection of the proof mass is determined by measuring the differential capacitance.

This sensing method has the ability of sensing both dynamic acceleration (i.e. shock or vibration) and static acceleration (i.e. inclination or rotation).

Signal conditioning is carried out within the **Geosense® MEMS Digital Tilt Beam** so that a simple serial output is obtained (RS485).

The MEMS sensors within **Geosense® MEMS Digital Tilt Beams** are configured measure inclination from vertical. As movement occurs, the **Geosense® MEMS Digital Tilt Beam** will move with its mounting, thus changing the inclination of the internal sensors.

The MEMS sensors **within Geosense® MEMS Digital Tilt Beams** measure tilt over a range of +/- 15°. Once mounted on a structure they are normally adjusted to read close to zero, their mid-point. An '**initial reading**' is then recorded and any changes in the inclination of the structure are identified by comparing the current readings with the initial readings.

Whilst the major advantage of MEMS based measuring systems, over the older electro-level based systems, is their stability and reduced thermal sensitivity, MEMS sensors are also significantly less likely to suffer from 'long term drift'. The 'solid state' construction and robust nature of the MEMS based systems, makes them very suitable for use in geotechnical instrumentation as the instruments are often located in areas that are highly prone to shocks and varying thermal conditions.

2.0 CONFORMITY

Geosense Ltd

Nova House
Rougham Industrial Estate
Rougham, Bury St Edmunds
Suffolk , IP30 9ND
United Kingdom

Tel: +44 (0)1359 270457, Fax: +44 (0)1359 272860
www.geosense.co.uk

EC Declaration of Conformity

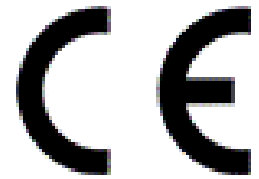

We Geosense Ltd at above address declare that the equipment detailed below, complies with the requirements of the following EU Directives:-

- Electromagnetic Compatibility Directive 2014/30/EU
-
- Restriction on the use of certain Hazardous Substances (RoHS2) 2011/65/EU

Equipment description: MEMS Digital Tilt Beam
Make/Brand: Geosense
Model Numbers: IPTB-H-485, IPTB-V-485,

Compliance has been assessed with reference to the following harmonised standard:

EN 61326-1:2013 Electrical equipment for measurement, control and laboratory use. EMC requirements. General requirements.

EN 61010 (2010) Safety requirements for electrical equipment for measurement, control, and laboratory use. General requirements

A technical file for this equipment is retained at the above address.

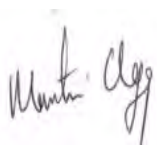
A handwritten signature in black ink, appearing to read "Martin Clegg".

Martin Clegg
Director
Rougham, November 2017

3.0 MARKINGS



TILT SENSOR	PRODUCT	MEMS In-place Tilt Beam	
	TYPE	IPTB - H - 485	
	RANGE	+/-15°	Supply: 8-15VDC
	SERIAL NO	XXXXX	Output: RS 485
  		www.geosense.co.uk t +44(0)1359 270457	



A **Geosense® MEMS Digital Tilt Beam** is labelled with the following information:-

Manufacturers telephone number & website address

Product group: Tilt Sensor

Product : MEMS Tilt Beam

Type: IPTB - H - 485, IPTB - V - 485

Range: +/- 15°, +/- 10°, +/- 5°

Orientation: Uni-axial

Input supply: 8-15 Volts DC

Output signal: Digital RS-485

Serial number: XXXXX

CE mark

WEEE mark

4.0 DELIVERY

This section should be read by ALL users of **Geosense® MEMS Digital Tilt Beams**

4.1 Packaging

Geosense® MEMS Digital Tilt Beams are packed for transportation to site. Packaging is suitably robust to allow normal handling by transportation companies. Inappropriate handling techniques may cause damage to the packaging and the enclosed equipment. The packaging should be carefully inspected upon delivery and any damage **MUST** be reported to both the transportation company and **Geosense®**.

4.2 Handling

Whilst they are a robust devices, **Geosense® MEMS Digital Tilt Beams** are precision measuring instruments. They and their associated equipment should always be handled with care during transportation, storage and installation.

Once the shipment has been inspected (see below), it is recommended that **Geosense® MEMS Digital Tilt Beams** remain in their original packaging for storage or transportation.

Cable should also be handled with care. Do not allow it to be damaged by sharp edges, rocks for example, and do not pull on the cable as this may damage the internal conductors and could render an installation useless.



DO NOT DROP AS THIS MAY CAUSE DAMAGE TO INTERNAL COMPONENTS

4.3 Inspection

It is important to check all the equipment in the shipment as soon as possible after taking delivery and well before installation is to be carried out. Check that all the components detailed on the documents are included in the shipment. Check that the equipment has not been physically damaged.

Geosense® MEMS Digital Tilt Beams carry a **unique** identification serial number and are supplied with individual calibration sheets.

Calibration Sheets contain VITAL information about the Tilt Beams. They should be stored in a safe place and only copies should be taken to site.



4.4 Storage

Geosense® MEMS Digital Tilt Beams are precision instruments containing sensitive electronics within tilt module. Whilst the Tilt Beam and module are robust placing heavy objects on top may cause bending of the beam and potential internal damage to the electronics.

It is recommended that Tilt Beams are stored in their original packing or in suitable protective boxes.

It is also recommended that any associated cables be stored in a dry environment to prevent moisture migrating along inside them in the event of prolonged submersion of exposed ends. Protective caps should be fitted during storage.

Storage areas should be free from rodents as they commonly damage connecting cables.



DO NOT STACK HEAVY OBJECTS ON TOP OF TILT BEAMS AS THIS COULD DAMAGE THE ELECTRONICS / CAUSE BENDING OF THE BODY/ DAMAGE THE MOUNTINGS

5.0 INSTALLATION

This section of the manual is intended for all users of **Geosense® MEMS Tilt Beams** and is intended to provide guidance with respect to their installation.

It must be remembered that no two installations will be the same and it is inevitable that some 'fine tuning' of the following procedures will be required to suit specific site conditions.

5.1 Preliminary Considerations

Prior to installation of **Geosense® MEMS Digital Tilt Beams** it is essential to establish and confirm details of the installation to be carried out. Some of the main considerations are listed below :-

- a. Structure / Installation location. The location of the installation can have implications with regard to planning, access and environmental considerations. For example, a city structure installation would demand different considerations than a dam face application.
- b. Structure / Installation type. The main consideration is access. The installation of tilt meters on a lift shaft, for example, requires special attention, whereas installation on the face of a low retaining wall requires less consideration, perhaps.
- c. Intended Position. This will usually be specified by the monitoring system designer and will be defined by the changes to be measured. However, some 'on-site' adjustments may be necessary but any changes should be approved by the system designer. Considerations such as the proximity of moving plant or other vibrations will also need to be addressed.
- d. Mounting requirements. Mounting brackets can be configured for almost any type of structure. This is best discussed and agreed with all interested parties, well before the installation is to be carried out.
- e. Connections. The selection of the most suitable and appropriate method of linking the sensors to a convenient readout location will depend upon many factors and should be decided upon prior to ordering the equipment (see section 5).
- f. Location of readout / data logger (as required). This must take into account the connection method selected, in addition to the EMI generated by adjacent and local equipment and cables.
- g. Protection of the Tilt Beams & cables from physical damage.

5.1.1 Tools & Consumables

The following is a brief list of tools and equipment typically used during the installation:-

- Electric Drill
- Suitable Drill Bits
- Spirit Level
- Through Bolts or Resin Groutable Anchors
- Set of spanners / adjustable spanners
- Marker
- Resin Grout (where required)

For the Bonded Anchors the choice of Bonding agent is critical. The material **MUST NOT CREEP** once it has cured. Any slight creep will result in changes in the sensor readings that will negate the value of the data.

Chemical Metal by 'Plastic Padding' is know for its resistance to creep and has been used for many years. Anchorset RED 300 by Everbuild is a more recent product.



Two examples of epoxy resins that exhibit the necessary 'No Creep' characteristics.



5.1.2 Cables & connections

Geosense® MEMS Digital Tilt Beams are supplied with connectors to allow them to be 'bussed' (interconnected) using a single cable and then a single cable routed to the readout location.

Planning of cable routes is critical together with protection of the cables, essential in any locations where they could be damaged.

Whilst long Tilt Beam strings (~1000m) should function without issue, depending on the system and environment suitable boosters may be required. Please contact Geosense® for advice.

5.1.3 Readout connection

Geosense® MEMS Digital Tilt Beams support RS485 serial communication using Geosense custom commands. The Tilt Beam connection lead has four insulated cores with the following assignment.

Wire Colour	RS485 Assignment
Brown	12V DC
White	Ground
Blue	A+
Black	B-

Geosense® MEMS Digital Tilt Beams readings can be obtained using Digital Tilt software (Windows Desktop) along with the Geosense R232/USB to RS485 interface. Other programs which allow serial communication such as HyperTerminal can also be used.

5.1.4 Wireless Connections

In congested locations where wired connections would be difficult, the use of the **Wi-SOS 480** wireless system may be a more appropriate data logging solution.

Here each tilt string is locally wired to a **Wi-SOS 480** Node which transmits the data to a central Gateway which can be accessed via the Internet. The **Wi-SOS 480** Node is pre programmed with the Geosense custom commands requiring no management of the serial communication and supports the RS485 specification requiring no additional serial interface. Please see the Wi-SOS 400 manual for further details.

5.1.5 Data logger Connections

The **Geosense® G8 PLUS** data logging system built around the **Geosense® G8** module is pre programmed with the Geosense custom commands. It contains 2 ports which supports the RS485 protocol which can be expanded with the use of a digital mux. No management of serial communication or serial interface is required.

The **Geosense® GL** data logging system built around Campbell Scientific Data loggers require the management of serial communication using LoggerNet to programme the logger. Some data logger modules also require the RS232/USB to RS485 interface.

5.1.6 Functionality testing

Prior to installation of the **Geosense® MEMS Digital Tilt Beams** it is recommended that they are always checked for correct operation. Each Tilt Beam is supplied with a calibration sheet which shows the accuracy of the device.

Connect the cable to a readout (as outlined in section 5.1.3) and place the Tilt Beam on an approximately horizontal surface and observe the reading (section X.X.X). The readings should be close to the factory **ZERO** reading on the calibration sheet. Note the output of the sensor is $\sin(x)$.

5.2 Installation procedures - introduction

Geosense® MEMS Digital Tilt Beams can be mounted as follows:-

- Vertically - as single sensors or in multiples to form a string
- Horizontally - as single sensors or in multiples to form a string

Tilt Beams measure rotation of the beam on a single axis along their length.



TILT BEAMS MUST BE ORIENTATED CORRECTLY

5.2.1 Markings / Orientation

All **Geosense® MEMS Digital Tilt Beams** marked as shown below to ensure correct orientation.

5.2.1.1 Horizontal Beam Markings

When mounted horizontally a clockwise rotation of the beam will output a positive reading.

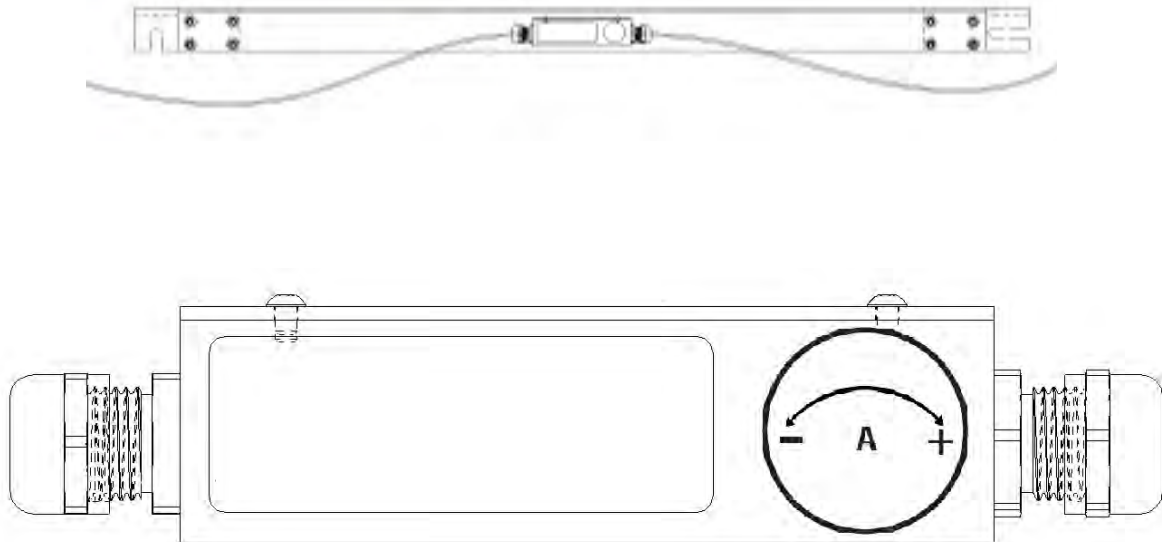

5.2.1.2 Vertical Beam Markings

When mounted vertically against a wall / surface rotation of the top of the beam away from the wall outputs a positive reading.

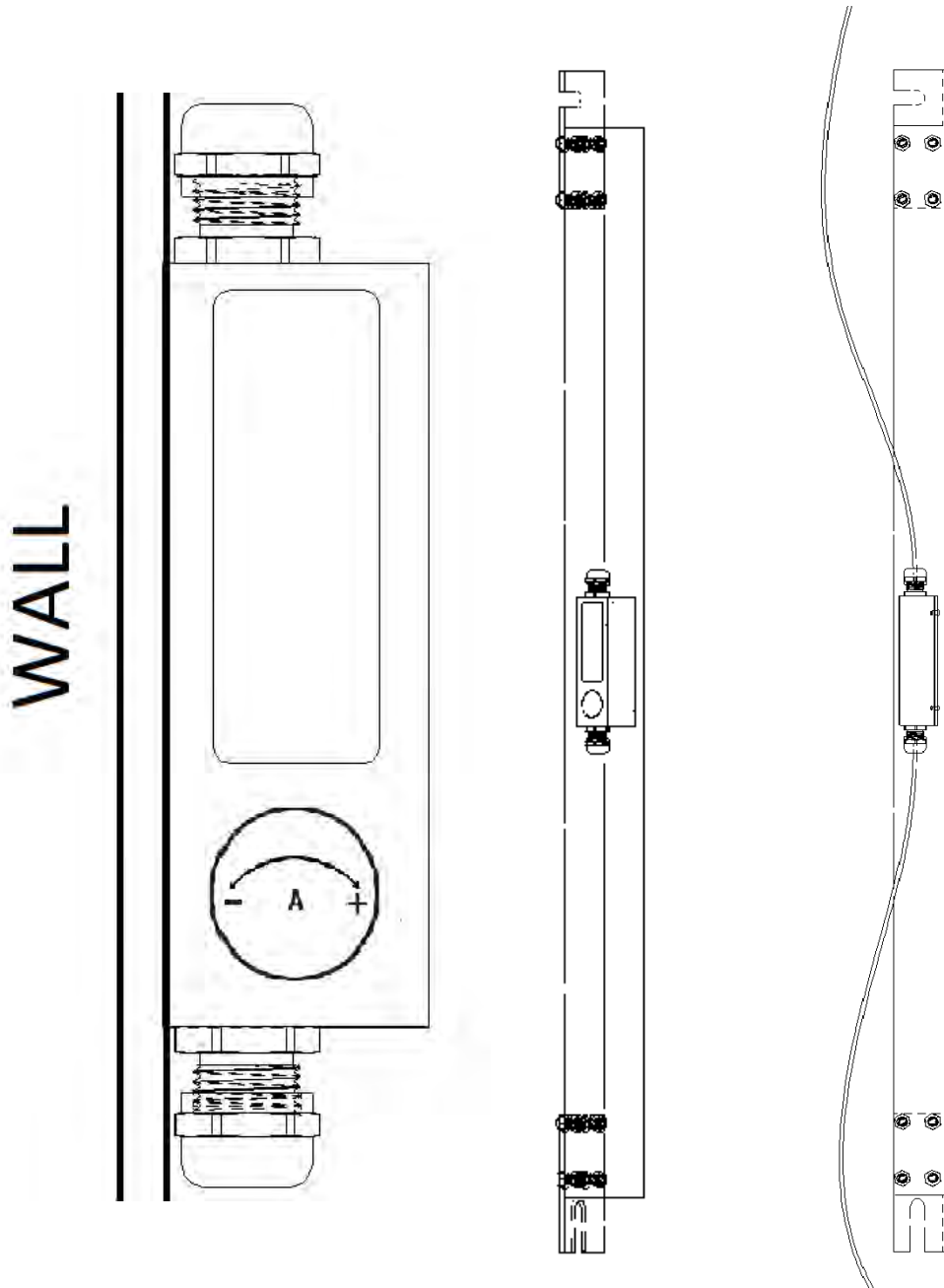

5.3 Anchor / Fixing Installation

The **Geosense® MEMS Digital Tilt Beams** are supplied with mounting brackets on each end of the beam which must be firmly supported. The hook end of the beam must be firmly gripped and the fork end gently gripped so as to prevent movement caused by vibration or slight knocks but allow longitudinal movement caused by thermal changes in the length of the beam. The mounting brackets connected to each end of the beam are shown below.

Hook end



Fork end

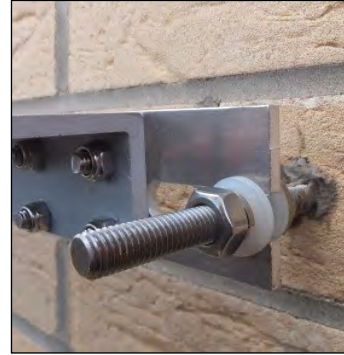

Many types of end anchor arrangements can be used to suit specific applications.

Geosense supply two common types of anchor:

- Through Bolt
- Resin Bonded Groutable Anchor

5.3.1 Through Bolts

Through bolt anchors are particularly suitable for good quality concrete, rock or good, competent brickwork. **These are not suitable for use in loose or friable materials.**

The hole into which they are fixed is the same diameter as the outside diameter of the threaded bolt. The drill bit required will for an M10 through bolt (the recommended size) will be a 10mm diameter masonry bit.

1. Mark the position of the first mounting anchor.
2. Set the depth gauge on the drill or mark the required depth on the drill bit.
3. Ensure the mounting surface at the intended location is clean and free of any obstructions that may affect the ease of installation.
4. Drill the anchor hole to the required depth.

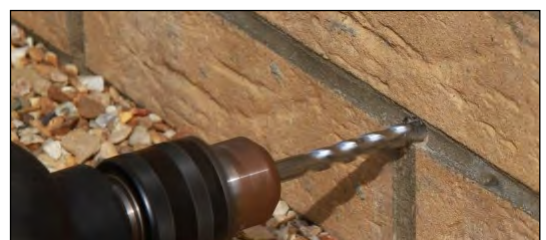
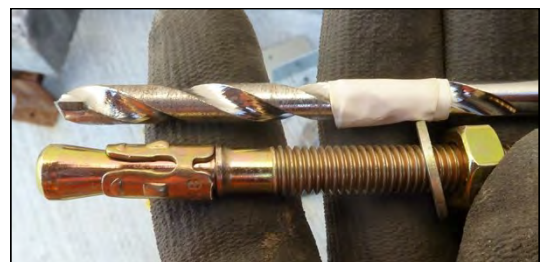

5. Using a hammer, drive the bolt into the required depth. Remember that this fixing will pull out a little as it is tightened, so as to engage the sleeve and grip the wall.
6. Tighten the nut down onto a washer to engage the anchor. Check that the fixing is tight.



Continue with installation of the beams and fixings as detailed in Sections 5.4 and 5.5.

5.3.2 Resin Bonded Groutable Anchor

Groutable anchors are available in many forms. A 'deformed', stainless steel, M10 threaded bar is used for this application.

1. Drill a hole slightly larger than the maximum diameter of the anchor.
2. Clean out the hole thoroughly. If possible, use a brush to clean the sides of the hole and a pump to blow out the dust.
3. Inject resin grout into the hole, starting at the deepest point, so as to fill the hole completely.

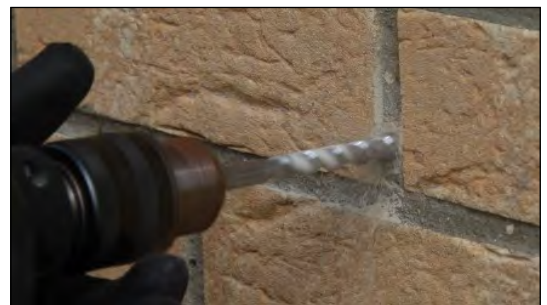
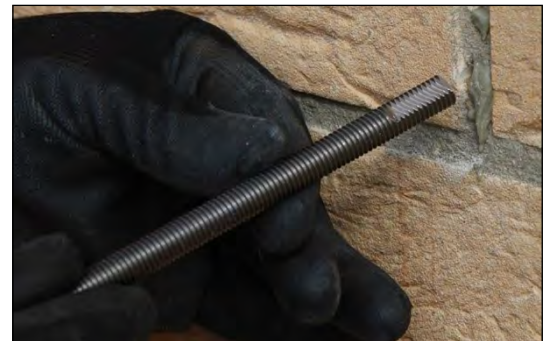

5.3.2 Resin Bonded Groutable Anchor contd...

1. Carefully push the deformed end of the anchor into the resin filled hole.



2. Rotate the anchor as it is pushed in.



3. Allow the resin grout to cure before proceeding with the beam installation. See resin grout instructions for correct curing times.



5.4 Horizontal Installation (Vertical Mount)

Horizontally mounted sensors can be mounted singly or interconnected to form a chain. The following installation procedure briefly describes the steps for an interconnected arrangement. Single beam installations use the same mounting configurations.

Where a chain of sensors is to be installed, it is best to select a position where the chain would be un-broken. This will simplify both the installation and the data analysis. However, as each installation is unique, this is not always possible so the installation must be tailored to achieve the best possible continuity.

Ensure the mounting surface at the intended location is clean and free of obstructions that may affect the installation. The beam locations should be in an area where they are unlikely to be knocked or disturbed.

Beams are manufactured with the fixed (HOOK) end on the LEFT hand end of the beam and the 'sliding' (FORK) end on the RIGHT hand end of the beam

Where possible, begin the installation on the Left of the beam / string of beams.

1. Having selected a suitable installation location, and installed the first anchor, as described in the previous sections, fit the supplied nuts and washers as shown for the FIXED end of the beam (Left end).

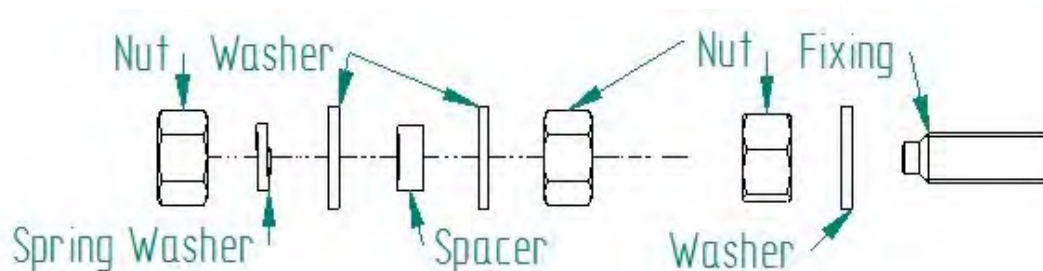

2. Slip the 'Hook' end of the beam over the Nylon spacer and adjust all the nuts and washers so that the beam sits as close to the wall as is practical, without touching the wall.

Take care that the hook remains on the Nylon spacer.

3. Align the beam using a spirit level
4.and mark the wall in the **centre** of the 'sliding' 'Fork' end mounting.

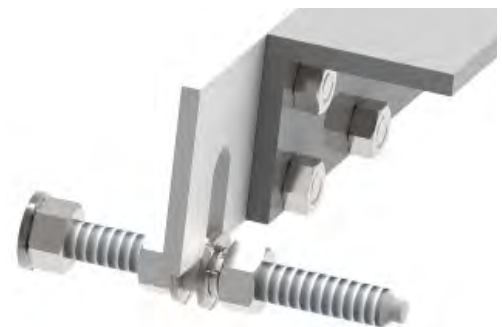

5.4 Horizontal Installation contd...

5. Install the next anchor as described in Section 5.2 and if this is to be an intermediate anchor in a string, fit the nuts and washers.

The fixed 'Hook' end of the beam is always at the back so that the nuts can be tightened firmly onto the steel washers.

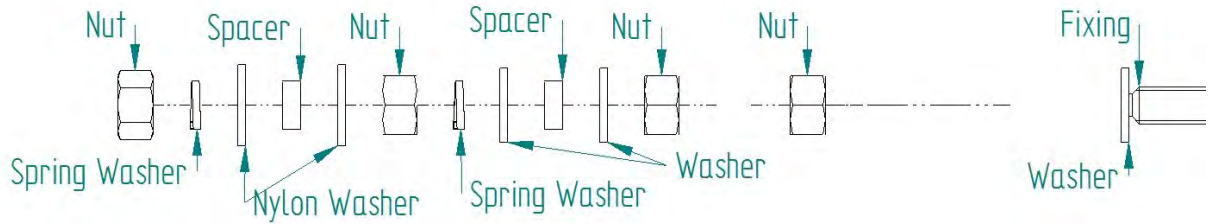

6. If the anchor is for the sliding 'Fork' end only, then fit the nuts and washers as shown here.

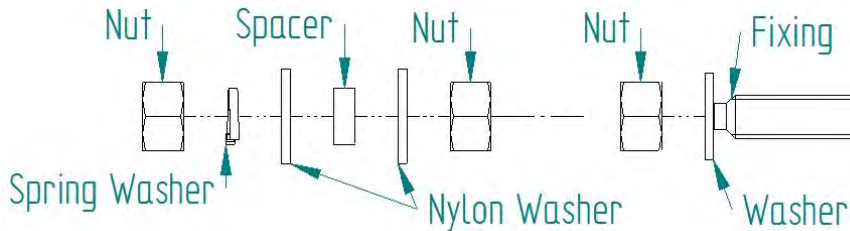

For a string of beams, work sequentially along the wall installing the anchors. If possible **install all the anchors before installation of the beams**. Fit the nuts and washers as to suit each anchor position in a string.

7. To fit the beams, work from the Right hand end of a string towards the left hand end. This allows for the tightening of the fixed beam ends behind the sliding ends.

Position the sliding 'Fork' end over the Nylon spacer washer, between the two Flat Nylon washers. Ensure there is adequate space for any expansion or contraction of the beam.



8. Drop the other end (the 'HOOK') over the next anchor, taking care that it fits over the Nylon spacer and between the Flat Steel washers.

Tighten the nut on the HOOK end using a spanner (or pair of spanners). This is the fixed end so the nuts must be tight.



5.4 Horizontal Installation contd...

9. Add the FORK end of the next beam, again ensuring that the Nylon spacer remains within the fork.
10. Check that the 'Fork' end is correctly supported on the anchor, in roughly its mid-point and loosely tighten the nut, making sure that the beam is not touching the structure.
11. **Carefully tighten the nut on the FORK.**

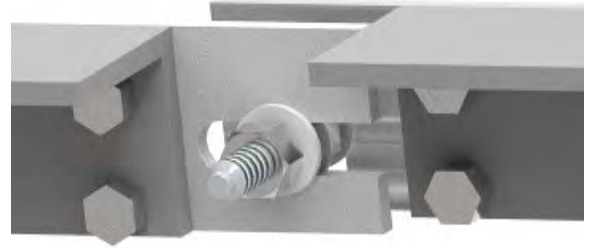

Tighten the nut until the spring washer is partially, **NOT** fully flattened (see right). This will be only a little tighter than 'finger tight'. This will ensure that the beam can't move on its anchor but linear thermal expansion / contraction can be accommodated without stressing or deforming the beam. Tighten the nuts on the 'HOOK' end.



If another beam is to be added to the string repeat the sequence using the same procedure.

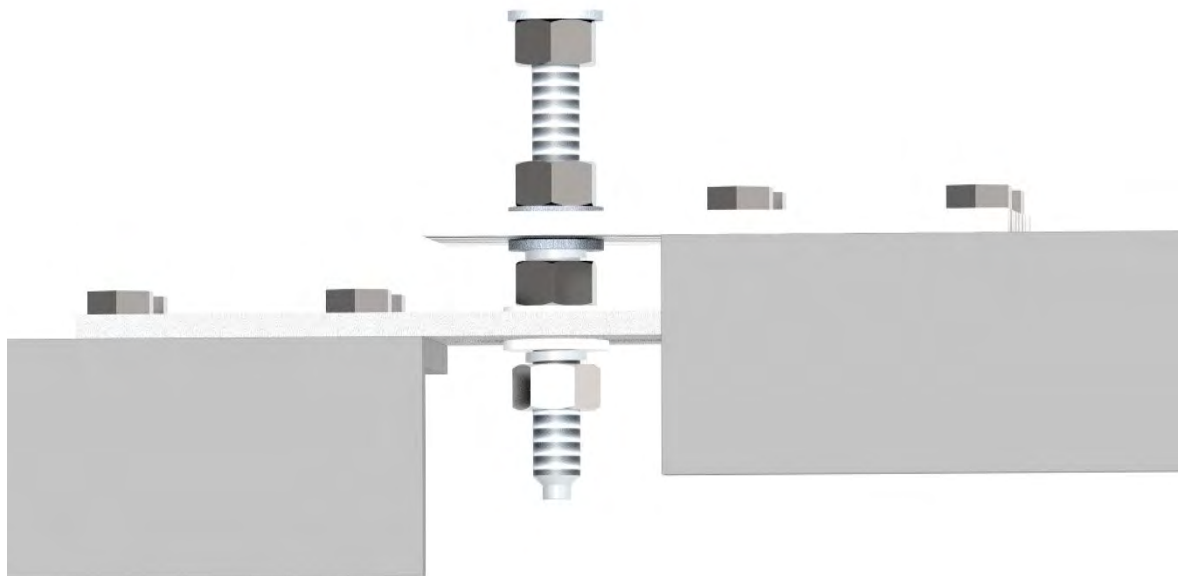

ONCE TIGHTENED IT SHOULD BE POSSIBLE TO MOVE THE FORK END WITHOUT EXCESSIVE FORCE

5.4 Horizontal Installation contd...

12. **Geosense® MEMS Digital Tilt Beams** are supplied with over moulded connectors for interconnection.
13. A male connector is fitted to the left of the tilt beam and the female connector fitted to the right end of the tilt beam. For this reason it is important to know to which end of the tilt beam string the logger will be connected to.



Geosense® provide either a male fly lead with female termination or female fly lead with male termination.

14. At the end of a string of beams the free end of the cable should be fitted with the end of line termination.

The terminator should be protected from damage by securing it to the tilt beam using a cable tie.

5.5 Horizontal Installation (Horizontal Mount)

In some installations it may be necessary to mount **Geosense® MEMS Digital Tilt Beams** horizontally for example on the top of a wall / structure. In this scenario **Geosense®** can supply a tilt beam L bracket G40-162.

1. Fix a vertical anchor into the horizontal surface using the same method as shown in Section 5.3. Once set fit the bottom set of nuts and washers onto the anchor. The top nut can be used to adjust the height of the installation.
2. Slide the L bracket onto the anchor followed by the final washer and nut.
3. Orientate the L bracket and tighten to secure in place. The Tilt Beam can now be installed in the same method as the vertical installation.

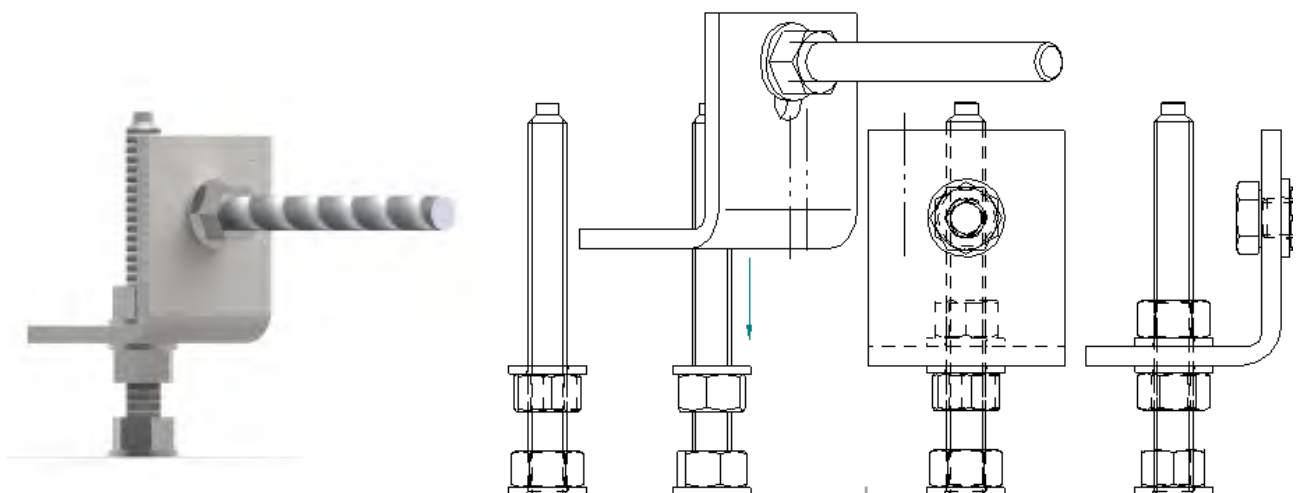

5.6 Vertical Installation

As with the Horizontally mounted sensors, the Vertically mounted sensors can be mounted singly or interconnected to form a chain. The following installation procedure briefly describes the steps for an interconnected arrangement. Single beam installations use the same mounting configurations at either end. Readout cables for single beams can either be routed from each individual beam to a terminal location or linked together from beam to beam.

Where a linked chain of beams is to be installed, it is best to select a position where the chain would be un-broken. This will simplify both the installation and the data analysis. However, as each installation is unique, this is not always possible, so each installation must be tailored to achieve the best possible continuity.

Ensure the mounting surface at the intended location is clean and free of obstructions that may affect the installation. The beam locations should be in an area where they are unlikely to be knocked or disturbed.

Beams are manufactured with their fixed 'HOOK' end on the TOP end of the beam so that it hangs from this end and the cable entry on the LEFT of the beam. If the beam anchors are to be installed from the bottom upwards, the beam used to set the anchor centres should be inverted so that the 'HOOK' end sits on the lower bolt when marking the position of the next bolt (working up the chain).

Where possible complete the installation of the anchors, then install the beams, so as to follow a systematic mounting sequence.

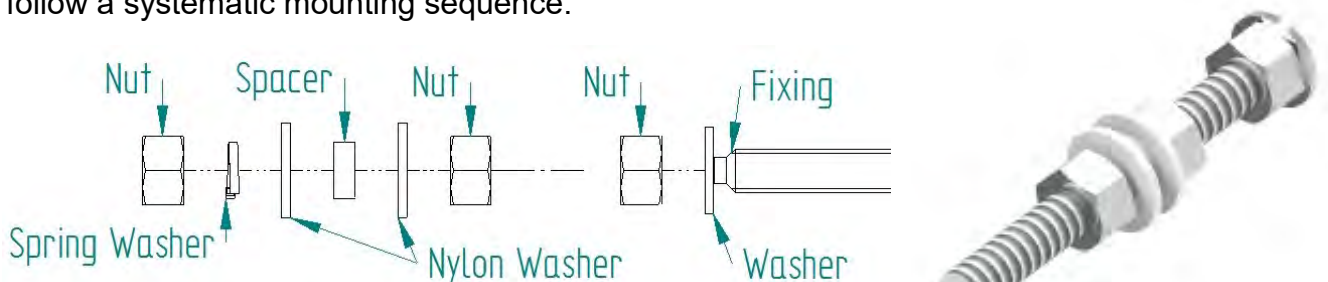

1. Mark the lowest mounting point and install the lowest anchor. Fit the nuts and washers to the lowest anchor, as shown above (for the 'FORK' end).
2. Mark the next fixing point location either using a tape measure or using the Tilt Beam as a guide ensuring the fixings are vertical. Fit the nuts and washers for an intermediate mounting as shown below.

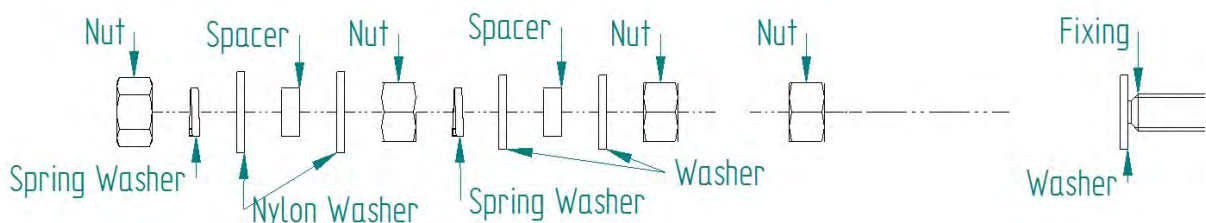

5.6 Vertical Installation contd...

3. Continue this process until all (or a number) of the anchors are installed and fitted with nuts and washers.
4. The final anchor on a string will be a 'Fixed' end so the nuts and washers should be fitted as shown below.

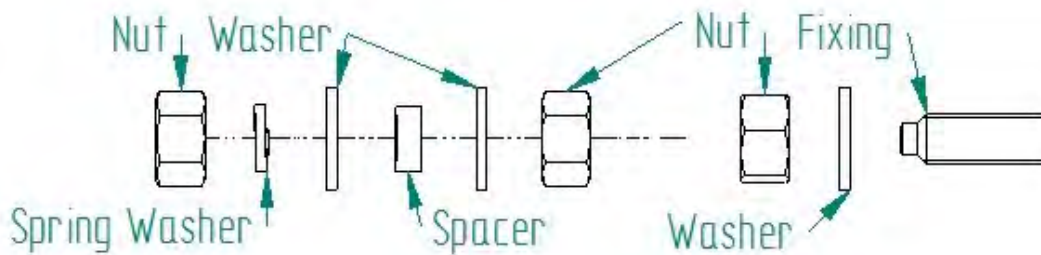

5. It is recommended that the beam installation begins at the lower end of a vertical string so that nuts can be tightened in the correct sequence. Fit 'FORK' end over the lowest anchor, ensuring that it sits over the Nylon spacer and between the two Nylon washers.
6. Lift the beam slightly and slide the 'HOOK' over the next anchor, ensuring it fits over the Nylon spacer and between the two steel washers. Ensure that the 'HOOK' end is pushed in fully over the anchor and on the Nylon ferrule. Tighten the nuts to grip it firmly (*this is the Fixed end*).
7. Tighten the nuts on the lower end (FORK END) of the beam. Tighten the nut until the spring washer is partially, **NOT** fully flattened (see below). This will ensure that the beam can't move on its anchor but linear thermal expansion / contraction can be accommodated without stressing or deforming the beam.

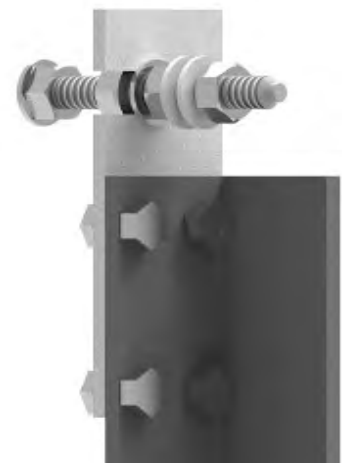
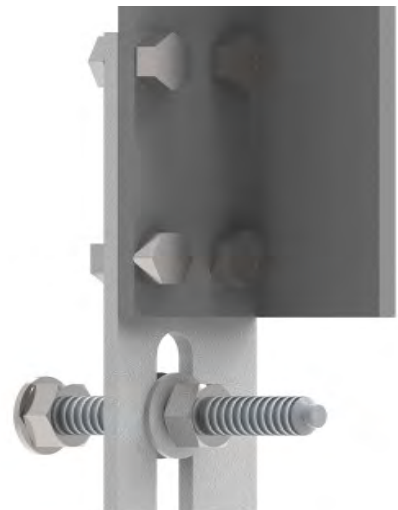

5.6 Vertical Installation contd...

8. Fit the lower 'FORK' end of the next beam to the outer washers of the upper anchor of the previous beam and slot the 'HOOK' end onto the next highest anchor. Tighten the nuts onto the 'Hook' end.
9. Follow the procedure described above for all subsequent beams. The uppermost anchor in a string will be the fixed 'Hook' end.
10. Once all the beams have been installed, it is necessary to check the torque on the nuts holding the 'sliding' ends of the beams.
12. **Geosense[®] MEMS Digital Tilt Beams** are supplied with over moulded connectors for interconnection.
13. A male connector is fitted to the top of the tilt beam and the female connector fitted to the bottom end of the tilt beam. For this reason it is important to know to which end of the tilt beam string the logger will be connected to.
14. At the end of a string of beams the free end of the cable should be fitted with the end of line termination.

Geosense[®] provide either a male fly lead with female termination or female fly lead with male termination.

The terminator should be protected from damage by securing it to the tilt beam using a cable tie.



ONCE TIGHTENED IT SHOULD BE POSSIBLE TO MOVE THE FORK END WITHOUT EXCESSIVE FORCE

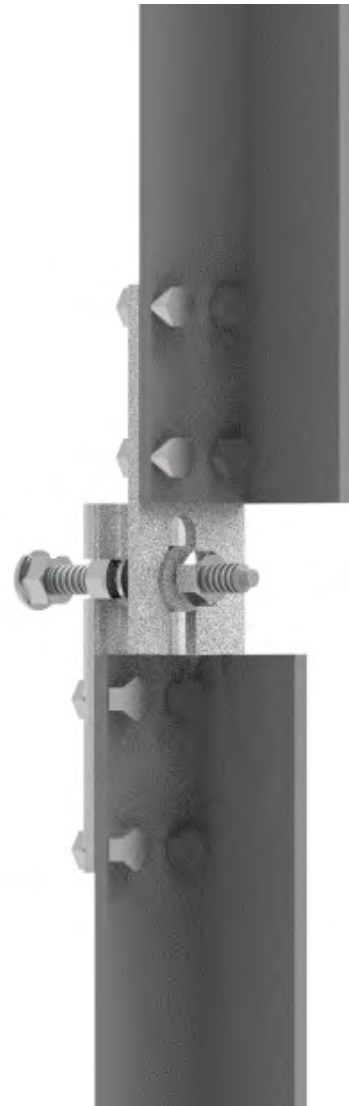

5.7 Electrical connections

Geosense® MEMS Digital Tilt Beams are fitted with a shielded 4 core twisted pair cable.

Wire Colour	RS485 Assignment
Brown	12V DC
White	Ground
Blue	A+
Black	B-

5.7.1 Extension cable

Where **Geosense® MEMS Digital Tilt Beams** are to be read at a distance from their installed location, an extension cable can be used to link them to a convenient readout point or to a data logger.

MEMS based sensors provide a digital output, thereby making them less prone to the negative effects associated with long or jointed cables than many other sensors.

However, they are NOT immune to the effects of high levels of EMI (Electro Magnetic Interference).

Consequently, it is important to use cable with a braided screen to ensure protection against harmful EMI and joined together using an EMC connection kit.

(Contact Geosense for further information).



ONLY USE BRAIDED SCREENED CABLE



ONLY USE EMC CABLE CONNECTION KITS

6.0 READOUTS

Sensors with a single or 'bussed' **Digital** outputs are intended for direct connection to a data logger but can also be interrogated using a windows tablet or PC.

6.1 Digital interface

Depending on what type of readout (Windows tablet) or DataLogger (not supporting direct RS485 connection) is being used, an RS-485 to RS-232 Interface module may be required (see below).

Wire colour	RS-485 colour IN	RS-232 colour OUT
V+ (Volt)	V	V
A +	A+	Tx
B-	B-	Rx
Ground	GND	GND

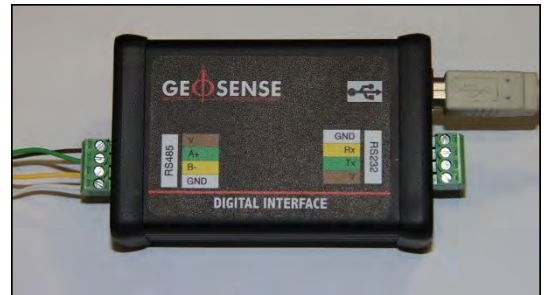

The **Geosense[®] Digital Interface** are supplied with two connection options:

1. USB (type B) for connection to a tablet or PC.
2. 4 wire screwed connector for direct RS232 connection to a data logger / RS232 port.

6.2 WI-SOS 480 Digital Node

The **Geosense[®] Tilt Beam** is fully compatible with the WI-SOS 480 Digital Node and is wired as shown below. (Please refer to the WI-SOS 480 manual for further details on configuration)

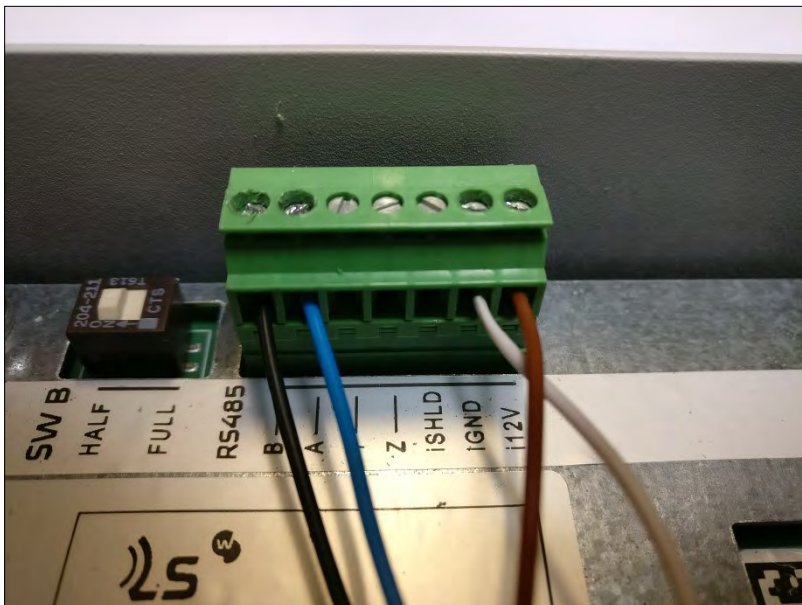

IPI conductor colour	Digital Node colour IN
V+ (Volt)	12V
A +	A+
B-	B-
Ground	GND

6.3 Windows Tablet / PC

The **Geosense® Tilt Beam** can be read directly with a Windows Tablet such as the Linx 10 shown below. The accessories that will be needed in addition are:-

- RS-485 to RS-232 Interface
- USB A to B (also known as a “printer cable”)

To carry out readings see section 7.2 Taking Readings on next page





6.4 Data loggers

Data loggers have the ability to automatically excite and interrogate a large number of sensors automatically combined with the ability to store large numbers of readings that might be associated with tilt monitoring.

This is the preferred and most common method of monitoring tilt beam installations and is the recommended method of interrogating multiple installations of **Geosense[®] MEMS Digital Tilt Beams**.

Since Digital RS485 is a common instrument outputs, it is possible to use a wide variety of data logging devices to record their readings. However, only those supplied by **Geosense[®]** are currently supported.

7.0 DATA HANDLING

The readings from **Geosense® MEMS Digital Tilt Beams** are already converted to engineering units within the board and are provided in the form of Sine of the angle of tilt. Consequently no additional calibration factors need be applied.

7.1 Direction convention

HORIZONTAL A-AXIS



POSITIVE READING



NEGATIVE READING

VERTICAL A-AXIS

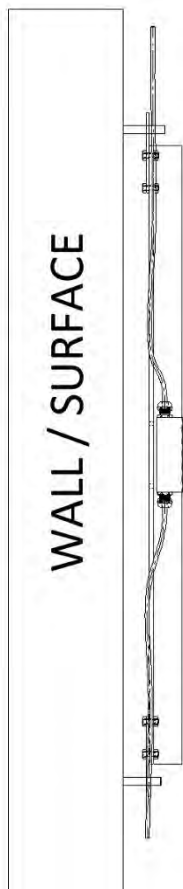

POSITIVE READING



NEGATIVE READING

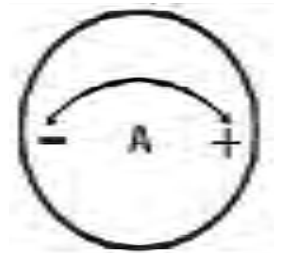



7.2 Taking Readings

Geosense[®] Tilt Beams are excited and interrogated using RS-485 digital protocols. A digital interface unit is required to connect from a standard RS-232C connection (as used by DataLogger, tablets, PCs, Notebooks or similar). **Geosense**[®] supply a dedicated RS232 to RS485 interface to be used with a Windows based device.

Once the installation has been carried out and all the thermal gradients have been removed, it is important to establish the initial reading for each of the Tilt Beams. Depending upon the reading method adopted, the initial readings may in either degrees or 'sine of degrees' (Sin(x)).

7.2.1 Geosense Tilt Beam Commands Format

All commands for the Geosense Tilt Beams have the format: @@XXXXX_Command<CR>

@@	=	Address detect character string
XXXXX	=	Serial Number / Address of Tilt Beam
_	=	Space Character (ASCII 32 / HEX 0X20)
Command	=	Commands in Section 7.1.3
<CR>	=	Carriage Return (ASCII 13 / HEX 0X0D)

The 65535 Serial number is used to communicate when connected to only a single sensor and the serial number of the sensor is not known.

7.2.2 Geosense Tilt Beam Commands

NULL Command @@XXXXX<CR><CR> (requires 2 carriage returns)

Example Command: @@12345<CR><CR>
Response: Geosense MEMS DIGITAL TILT Ver2.0 Serial# TM12345

TAKE READING Command @@XXXXX TR<CR>

Example Command: @@12345 TR<CR>
Response: TR

SEND READING Command @@XXXXX SR<CR>

Example Command: @@12345 SR<CR>
Response: SR 0.000123,-0.003242,20.0 (SR A Axis, BAxis, Temp)

7.2.3 Geosense Tilt Beam Error Messages

- Incorrect commands which are not correctly addressed to the sensor are ignored and produce no response.
- A correctly addressed but otherwise unknown command results in a query response:
@@12345 getreadings<CR>
Getreadings ?

7.2.4 G-Tilt Software—Quick Guide

The G-Tilt Software is only suitable for use on **Microsoft Windows** PC and tablets running full windows OS. The G-Tilt Software can be downloaded at <https://www.geosense.co.uk/technical/downloads>.

1. Install the software and once complete connect the USB cable from the Digital Interface to the PC. If this is the first time the Interface has been connected to the PC wait for the drivers to be installed, this may take several minutes.



If Windows does not automatically install the device drivers for the Digital Interface, it may be necessary to perform a Windows Update to locate the drivers from the internet

2. To identify the port number which the Interface has been assigned, use device manager and view PORTS. If multiple USB device are connected to the PC the interface can be removed and re connected to help identify it.
3. Once the Com Port has been identified navigate back to the G-Tilt application. Click the 'COM Port' tab and select the correct port. If the port is not present restart the software by closing and reopening it.

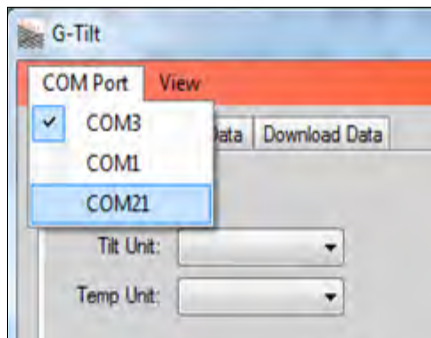
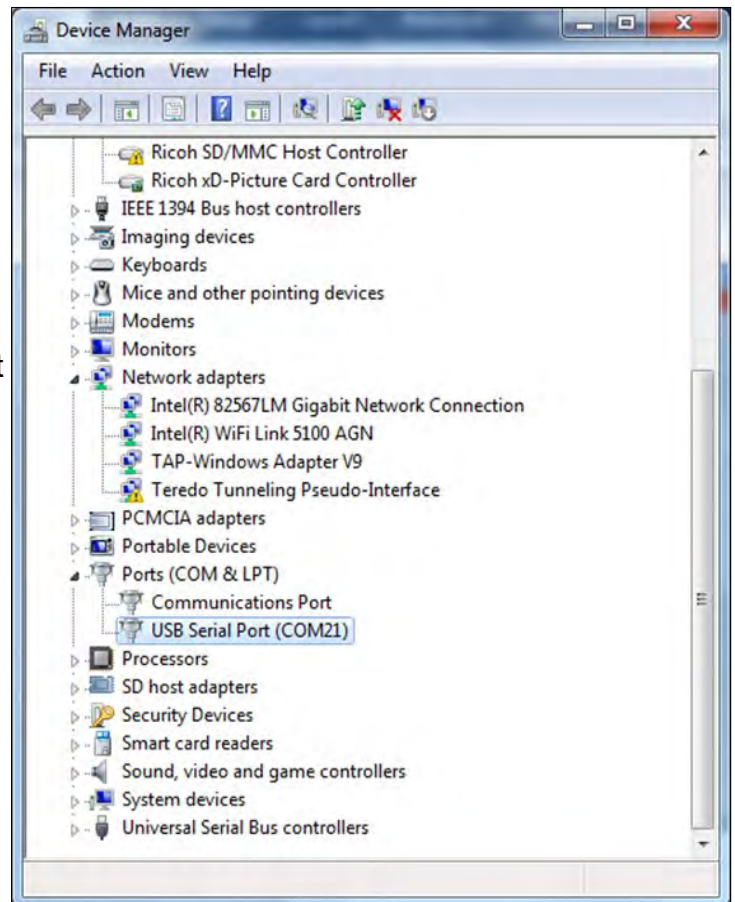

3. Select the preferred units of Tilt (Rotation) and Temperature from the drop down lists.

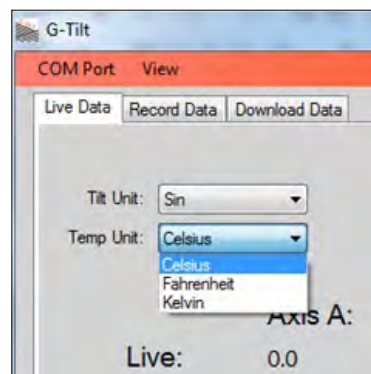
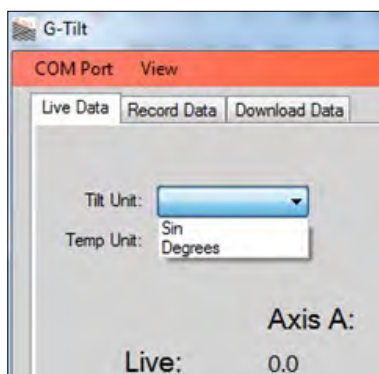

7.2.4 G-Tilt Software—Quick Guide contd...

4. Enter the Serial number of the sensor to be interrogated and press the 'Connect to Sensor' button.
5. Once connected the "LIVE" data will be displayed in the window, in the units selected.

These are 'absolute' values and must be referred to initial readings to assess any change in rotation.

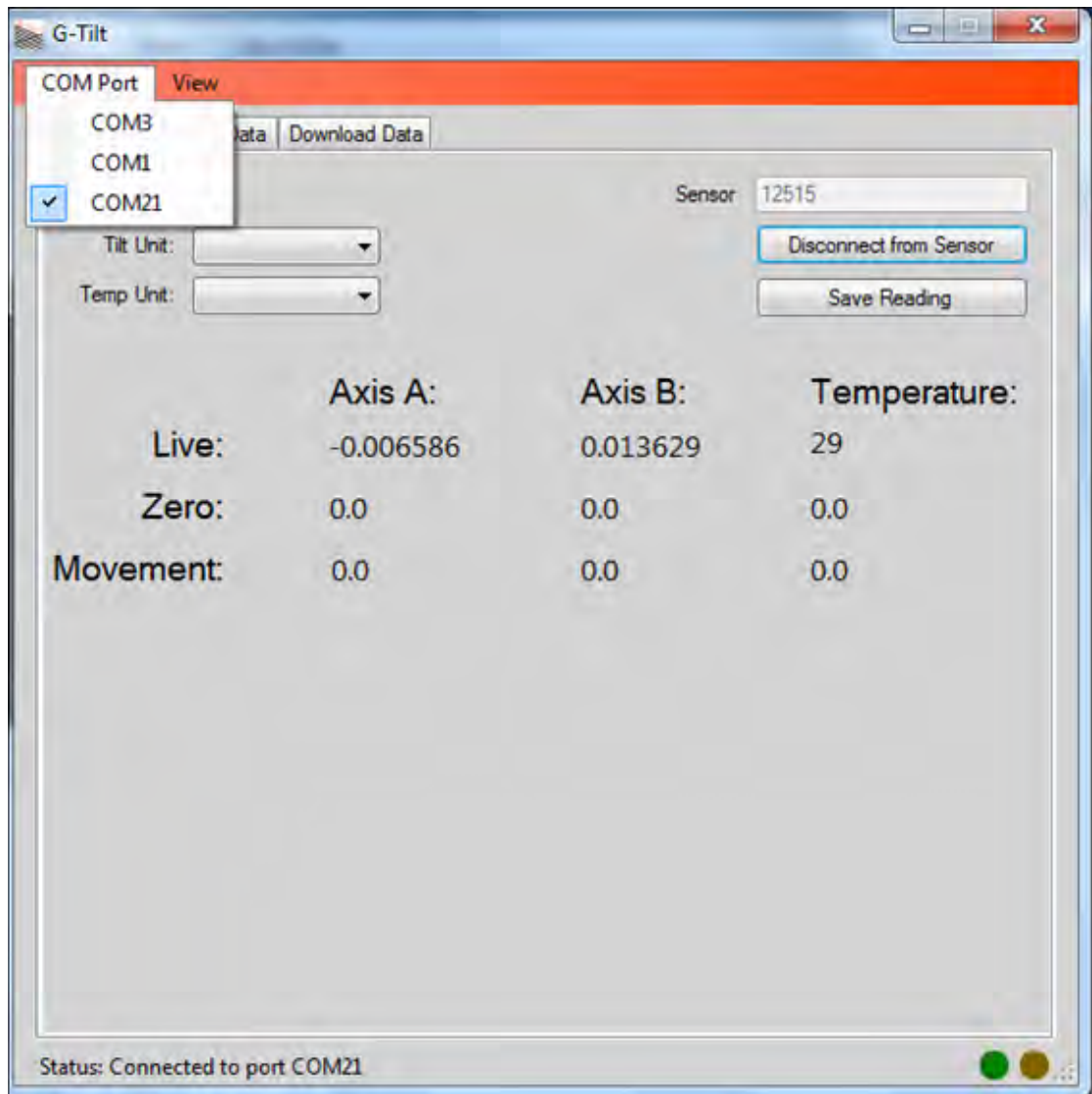
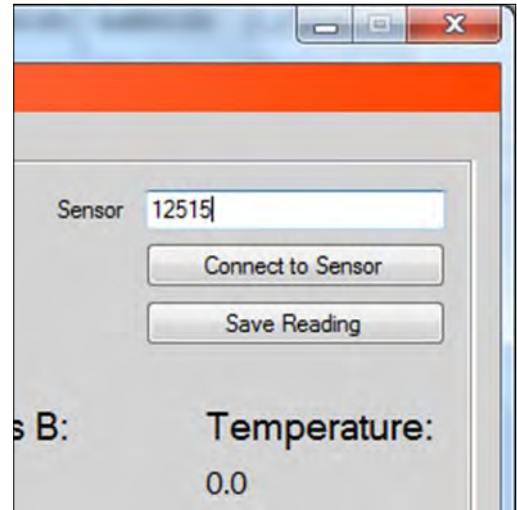

7.2.5 Tilt Checker Software

4. Enter the Serial number of the sensor to be interrogated and press the 'Connect to Sensor' button.
5. Once connected the "LIVE" data will be displayed in the window, in the units selected.

These are 'absolute' values and must be referred to initial readings to assess any change in rotation.

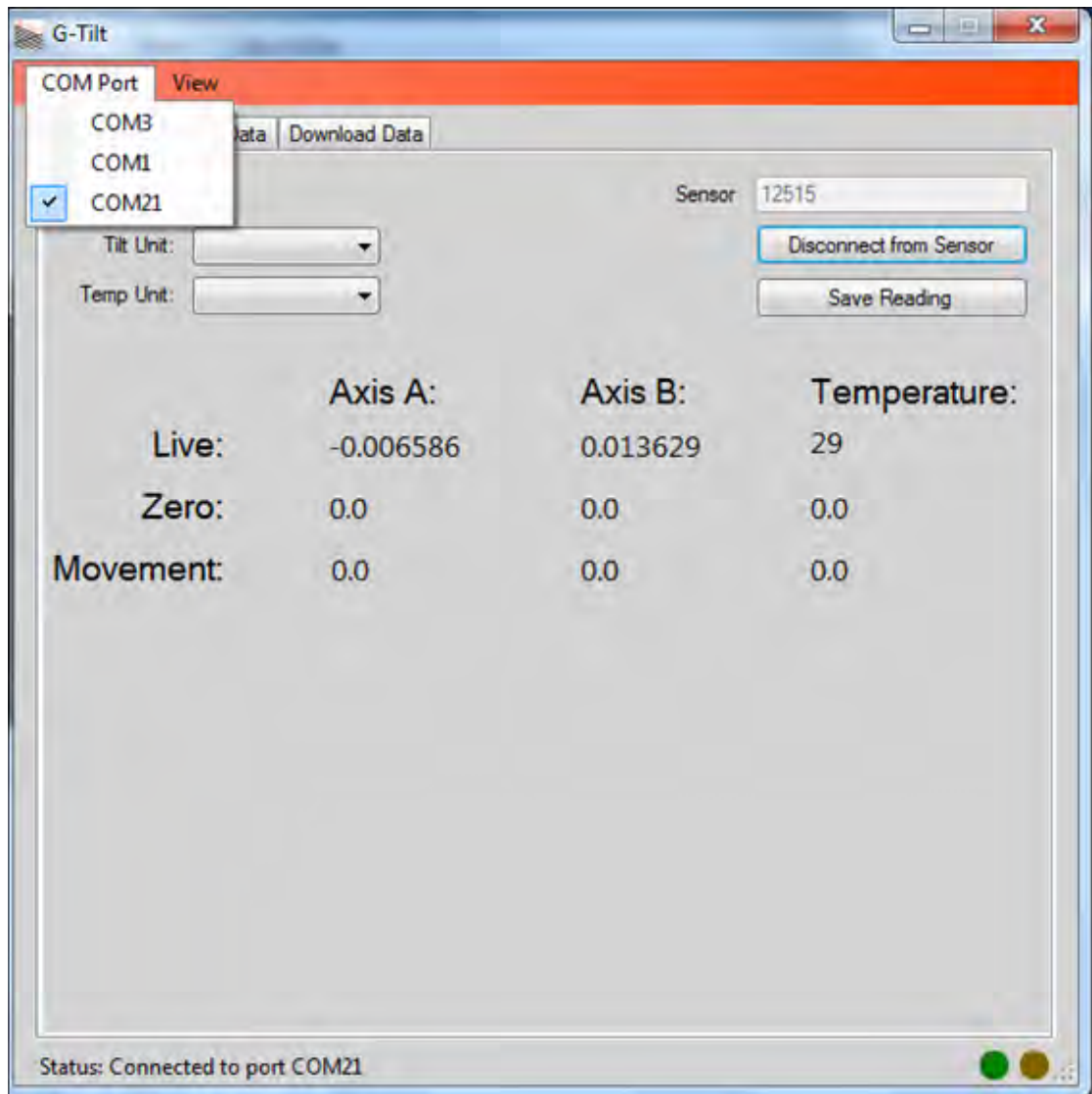
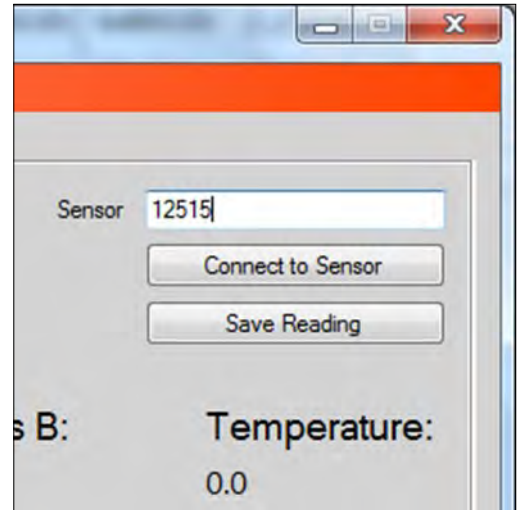

7.3 Data Conversion

The readings generated by Digital Tilt Beams are in 'Sine of the Angle' ($\sin(x)$).

- *Digital* : $-0.2588 \sin^{-1}$ to $+0.2588 \sin^{-1}$

The **Geosense® MEMS Digital Tilt Beam** is supplied with 8 - 15 volts to power the internal processor and sensors via the RS485 'bus' cable. Each sensor has a unique identification or 'address'. The interrogating logger or readout 'requests' a reading from a particular 'address'. The value returned from the processor is a value in \sin^{-1} (the sine of the angle with respect to vertical) which can then be easily converted into a reading in degrees or other engineering units.

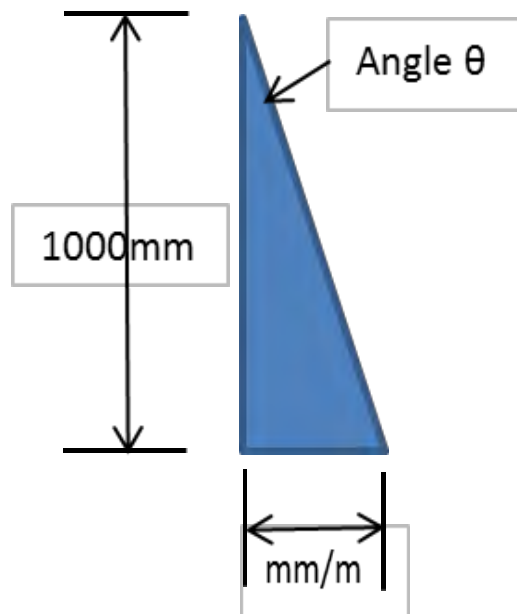

Whilst calibration records are provided for all sensors as a record they are not needed for any data conversion. They are only there to provide a reference if required.

Some examples of conversion from Tilt Meter output to other engineering units are shown on the next page.



YOU SHOULD ENSURE THAT YOU ALWAYS HAVE A BASE READING AS EVERYTHING IS MEASURED RELATIVE TO THIS. IT IS THE CHANGE IN READING THAT IS IMPORTANT



Readings from the Tilt Beam will be in Sine of the angle (Sin(x))

Sine of angle to degrees

$$\Delta Y = (\text{Base reading Sin}^{-1}) - (\text{Current reading Sin}^{-1})$$

Example $\Delta Y = (0.08716 \text{ Sin}^{-1}) - (0.17365 \text{ Sin}^{-1})$

$$\Delta Y = (5.000) - (10.000) = - 5.000^\circ$$

Sine of angle to mm/m

$$Y = (\text{Base reading Sin}^{-1}) - (\text{Current reading Sin}^{-1})$$

Example $\Delta Y = (0.08716 \text{ Sin}^{-1}) - (0.17365 \text{ Sin}^{-1})$

$$\Delta Y = (5.000) - (10.000) = - 5.000^\circ$$

$$\text{Sin } 5.000 = 0.08715$$

$$0.08715 \times 1000$$

$$= 87.15 \text{ mm / m}$$

7.4 Temperature effects

The Thermal influences on **Tilt Beams** are often complex. Therefore, in order to apply any correction for temperature changes it is first necessary to establish the effects of temperature changes on a particular **Tilt Beam** and, more importantly, on the structure to which it is attached.

To establish the true affects of temperature changes, it is necessary to observe the readings from a particular **Tilt Beam** over a period of thermal change, when little or no structural changes are taking place. This helps to identify the overall effects on the crack meter, the material on which it is mounted and the structure as a whole.

8.0 MAINTENANCE

Geosense® MEMS Digital Tilt Beams are maintenance free devices, for most applications. However should the unit be subjected to an impact, be producing “un-expected” readings or have been moved to another project after an extended period, it is recommended that they be returned to **Geosense®** for re-calibration.

9.0 TROUBLESHOOTING

In almost all cases, a fluctuating reading is a sign of a faulty signal from the sensor. The fault could be in either the sensor, the connecting cable, any switch boxes, the digital interface, or the readout. The best way to fault find an individual sensor is to isolate it from all others in a string and any connections. Where possible begin fault finding from the sensor or end of a string of sensors.

An additional resistance diagnostic check routines are also included to help identify problems with cables.

Fault finding assistance from the Digital Interface manual:-

Typically any failure or error in communication is due to the RS485 sensor being read and not the RS485-RS232/USB interface. However the interface can be checked by sending the command “menu” when it is first powered up. See the interface manual for assistance with this procedure.

Fault	Possible cause	Remedy
No Connection to the Interface	Incorrect wiring	Check wiring diagram for the RS232 or USB side.
No Connection to the Interface	Incorrect Settings - see the Interface manual	Settings on readout / logger Baud rate: 115200 Data Bits: 8 Stop Bits: 1 Parity: None
No Connection to a Sensor	Incorrect wiring	Check wiring diagram for the RS485 side.
No Connection to a Sensor	Incorrect Sensor Settings	Interface only supports baud rates of 9600 (RS485 side)
No Connection to a number of Sensors	Maximum Current Limited Exceeded	Supply RS485 sensor(s) externally
No Connection to a Sensor	Incorrect Command	Check RS485 Sensor manual for correct command structure

8.0 TROUBLESHOOTING contd....

Fault finding assistance for the cabling :-

Using a Resistance meter or Electrical Multi-meter set to measure resistance, check the resistance between each conductor and between each conductor and the drain wire or screen.

There should be a VERY high, or infinite electrical resistance between the conductors and the drain or screen (a value in M Ω 's is acceptable).

None of the individual conductors should be shorted to the screen or drain wire (showing Zero resistance) and none should be shorted together (showing Zero resistance).

As a terminal resistor is fitted to a string of IPI sensors, the resistance between the Yellow and the Green conductors and the should be in the order of 100 - 140 Ω .

The electrical resistance between the Brown and White, the power conductors will vary significantly depending on the number of sensors in the string. The resistance should never be Zero and should not exceed 2000 Ω .

10.0 SPECIFICATION

DIGITAL TILT BEAMS

MODEL	IPTM-M-5-1-485	IPTM-M-10-1-485	IPTM-M-15-1-485
Range	±5°	±10°	±15°
Axis	Uniaxial	Uniaxial	Uniaxial
Output	RS-485/BUS	RS-485/BUS	RS-485/BUS
Accuracy	±0.0013° ±4.68 arc sec ±0.02 mm/m ±0.013 %FS	±0.002° ±7.2 arc sec ±0.035 mm/m ±0.01 %FS	±0.004° ±13.5 arc sec ±0.065 mm/m ±0.0125 %FS
Resolution	0.0005° 2 arc sec 0.01 mm/m 0.005% FS	0.0005° 2 arc sec 0.01 mm/m 0.0025% FS	0.0005° 2 arc sec 0.01 mm/m 0.0017% FS
Repeatability	±0.002° ±7.2 arc sec ± 0.034 mm/m 0.02% FS	±0.002° ±7.2 arc sec ± 0.034 mm/m 0.01% FS	±0.002° ±7.2 arc sec ± 0.034 mm/m 0.007% FS
Sensor	MEMS	MEMS	MEMS
Excitation	8-15 V DC	8-15 V DC	8-15 V DC
Operating temperature	40 to +85°C	-40 to +85°C	-40 to +85°C
Dimensions	125x80x60mm	125x80x60mm	125x80x60mm

CABLES

Standard

TILT METER MODEL	CABLE	PART NUMBER
Digital uniaxial RS-485	2 twisted pair	Q10-151
Digital bi-axial RS-485	2 twisted pair	Q10-151

Low smoke halogen free (LSHF)

TILT METER MODEL	CABLE	PART NUMBER
Digital uniaxial RS-485	2 twisted pair	Q10-161
Digital bi-axial RS-485	2 twisted pair	Q10-161

LUL Approved

TILT METER MODEL	CABLE	PART NUMBER
Digital uniaxial RS-485	2 twisted pair	Q10-171
Digital bi-axial RS-485	2 twisted pair	Q10-171

11.0 SPARE PARTS

There are no spare parts available for **Geosense® MEMS Digital Tilt Beams**.

In the case of damage to the connectors on the readout unit or the tilt meter, Geosense can provide the replacement parts and a service to attach the connectors.

12.0 RETURN OF GOODS

12.1 Returns procedure

If goods are to be returned for either service/repair or warranty, the customer should contact **Geosense®** for a **Returns Authorisation Number**, request a **Returned Equipment Report Form QF034** and, prior to shipment. Numbers must be clearly marked on the outside of the shipment.

Complete the **Returned Equipment Report Form QF034**, including as much detail as possible, and enclose it with the returned goods and a copy of the form should be faxed or emailed in advance to the factory.

12.2 Chargeable Service or Repairs (Inspection & Estimate)

It is the policy of **Geosense®** that an estimate is provided to the customer prior to any repair being carried out. A set charge for inspecting the equipment and providing an estimate is also chargeable.

12.3 Warranty Claim (See Limited Warranty Conditions)

This covers defects which arise as a result of a failure in design or manufacturing. It is a condition of the warranty that the **Geosense® MEMS Digital Tilt Beams** must be installed and used in accordance with the manufacturer's instructions and has not been subject to misuse.

In order to make a warranty claim, contact **Geosense®** and request a **Returned Equipment Report Form QF034**. Tick the warranty claim box and return the form with the goods as above. You will then be contacted and informed whether your warranty claim is valid.

12.4 Packaging and Carriage

All used goods shipped to the factory **must** be sealed inside a clean plastic bag and packed in a suitable carton. If the original packaging is not available, **Geosense®** should be contacted for advice. **Geosense®** will not be responsible for damage resulting from inadequate returns packaging or contamination under any circumstances.

12.5 Transport & Storage

All goods should be adequately packaged to prevent damage in transit or intermediate storage.



13.0 LIMITED WARRANTY

The manufacturer, (Geosense Ltd), warrants the **Geosense[®] MEMS Digital Tilt Beams** manufactured by it, under normal use and service, to be free from defects in material and workmanship under the following terms and conditions:-

Sufficient site data has been provided to **Geosense[®]** by the purchaser as regards the nature of the installation to allow **Geosense[®]** to select the correct type and range of **Geosense[®] MEMS Digital Tilt Beams** and other component parts.

The **Geosense[®] MEMS Digital Tilt Beams** shall be installed in accordance with the manufacturer's recommendations.

The equipment is warranted for 1 year from the date of shipment from the manufacturer to the purchaser.

The warranty is limited to replacement of part or parts which, are determined to be defective upon inspection at the factory. Shipment of defective part or parts to the factory shall be at the expense of the Purchaser. Return shipment of repaired/ replaced part or parts covered by this warranty shall be at the expense of the Manufacturer.

Unauthorised alteration and/or repair by anyone which, causes failure of the unit or associated components will void this **LIMITED WARRANTY** in its entirety.

The Purchaser warrants through the purchase of the Geosense[®] MEMS Digital Tilt Beam equipment that he is familiar with the equipment and its proper use. In no event shall the manufacturer be liable for any injury, loss or damage, direct or consequential, special, incidental, indirect or punitive, arising out of the use of or inability to use the equipment sold to the Purchaser by the Manufacturer.

The Purchaser assumes all risks and liability whatsoever in connection with the **Geosense[®] MEMS Digital Tilt Beam** equipment from the time of delivery to Purchaser.



Geosense Ltd

Nova House . Rougham Industrial Estate . Rougham . Bury St Edmunds . Suffolk . IP30 9ND . England .

Tel: +44 (0) 1359 270457 . Fax: +44 (0) 1359 272860 .

email: info@geosense.co.uk . www.geosense.co.uk