

DynaLogger TcAs

Overview

The wireless **TcAs** sensor was developed to identify symptoms of failure modes or defects in **machines and equipment in general** in accordance with ISO 20816. Additionally, with triaxial spectra and a contact temperature sensor, the **TcAs** is capable of monitoring **unusual equipment and structures such as suspensions, servers, pipelines, and valves**. Furthermore, the solution includes an **online platform**, with no need for local installation, featuring various tools that assist in data analysis and allow for constant monitoring of asset health.

The IoT **TcAs** sensor has two monitoring modes: spectral/waveform and telemetry. The configurable **telemetry monitoring** includes global vibration and contact temperature metrics minute by minute. In **spectral monitoring**, different tools can be used: spectrum, waveform (linear, circular, and orbital), frequency filters, cepstrum, spectral envelope (demodulation), autocorrelation, and multi-metrics.



Wireless IoT Monitoring

- One of the smallest sensors on the market
- Long battery life
- Easy mounting
- High spectral resolution up to 91,200 spectral lines
- More than 200 time and frequency based metrics, in different bands, for alert creation
- Monitoring of rotating machines in general according to ISO 20816
- True simultaneous triaxial measurement
- Remote sensor updating

Main Applications

- Motors, pumps, and fans
- Machine structures: chassis, suspensions and springs, rails, etc.
- Pulleys and roller bearing housing
- Cardan shafts
- Bearings (more advanced defects - stage 3 or 4)
- Assets with lower criticality

TECHNICAL SPECIFICATIONS

Dimensions	36.6 mm x 33.6 mm x 18.7 mm (1.44 in x 1.32 in x 0.74 in)
Weight	33.8 g
Material	LEXAN™
Mounting	Glued
Visual Signaling (LED)	Red/green
Accelerometer	MEMS triaxial
Accelerometer Impact Limit	3,000 g in 0.5 ms
Operating Temperature ^{1,2}	-10 °C ≤ T ≤ 84 °C (14 °F ≤ T ≤ 183.2 °F)
Certified Operating Temperature for Explosive Atmospheres	-10 °C ≤ Tamb ≤ 79 °C (14 °F ≤ T ≤ 174.2 °F)
	-10 °C ≤ Tamb ≤ 88 °C (14 °F ≤ T ≤ 190.4 °F) batches ≥ 06 ³

BATTERY

Voltage	3 V
Autonomy ⁴	5 years

COMMUNICATION AND SYSTEM

Wireless Communication	Bluetooth® 5.3 / 2,400 - 2,483.5 MHz
Free Field Range ⁵	100 m
RF Output Power	0.4 dBm

CONTINUOUS MONITORING (TELEMETRY)

Monitoring Interval	1 to 60 min
Monitored Metrics	RMS Acceleration
	RMS Velocity
	Contact temperature
Temperature Resolution	0.01 °C (32.018 °F)
Frequency Bands	3 Hz to 2.5 kHz (adjustable)
Frequency Response (± 3 dB)	2 kHz
Dynamic Range	Up to ±16 g
Memory ⁶	51,200 samples (adjustable)

CERTIFICATION / HOMOLOGATION

See last page

1 - It is possible to monitor assets whose temperature exceeds 84 °C (183 °F), especially assets with intermittent characteristics and with room temperature below 24 °C (75 °F). However, Dynamox does not provide warranty in these cases. Specific condition for application outside explosive atmospheres. 2 - The application at temperatures below 0 °C (32 °F) impacts the battery autonomy. This effect worsens the lower the temperature, estimating a reduction of about 50% of useful life in applications at -20 °C (-4 °F). Specific condition for application outside explosive atmospheres. 3 - This temperature specification is valid for batches above DyL0.06.AXXXX of the TcAs model. 4 - Estimated value for a standard monitoring condition with 1 daily spectral collection, telemetry intervals of 5 minutes and operating temperature between 20 °C (68 °F) and 60 °C (140 °F). 5 - Reference in free field. Bluetooth® communication distance may vary with obstacles, interference and device (cell phone or Gateway). 6 - Each telemetry metric corresponds to the allocation of a sample in memory. In practice, the time to fill the memory depends on the sample interval and number of metrics configured. It is important to remember that when a data collection is performed (App or Gateway), the memory is emptied.

SPECTRAL MONITORING AND WAVEFORM

Analysis Tools	Spectrum
	Frequency filters
	Envelope (demodulation)
	Cepstrum
	Spectral waterfall
	Autocorrelation
	Circular and orbital waveform
	Advanced metrics: Multiband RMS, Envelope RMS, peak-to-peak, kurtosis, FC, FC+, carpet energy, energy at 1X and harmonics in velocity, and 1X BPFO, 1X BPFI, 1X BSF, 1X FTF in envelope and Envelope RMS.
Frequency Response ($\pm 5\%$)	2 kHz
Frequency Response ($\pm 3\text{dB}$)	2.1 kHz
Spectral Noise Density	$> 220 \mu\text{g}/\sqrt{\text{Hz}}$
Sample Rate	Up to 5,040 kHz
Min. Frequency Resolution	0.012 Hz
Min. Resolution in Amplitude ¹	16 mg
Amplitude Range	Up to $\pm 16 \text{ g}$
Lines of Resolution (LOR)	91,200 (uniaxial) and 30,400 (triaxial)
Max. Frequency	1,260 Hz to 2,520 kHz (adjustable)
Max. Collection Time ²	72.4 s (uniaxial) and 24.1 s (triaxial)

SPECTRAL MONITORING SETTINGS

TRIAxIAL SIMULTANEOUS

Max. Freq. (Hz)	Duration (s)						RPM Min. ³
2,520	0.41	0.81	1.63	3.25	6.5	12.1	5.0
1,260	0.81	1.63	3.25	6.5	13.0	24.1	2.5
N. Lines	1,024	2,048	4,096	8,192	16,384	30,400	-

UNIAXIAL

Max. Freq. (Hz)	Duration (s)								RPM Min. ³
2,520	0.41	0.81	1.6	3.3	6.5	13.0	19.5	36.2	1.7
1,260	0.81	1.6	3.3	6.5	13.0	26.0	39.0	72.4	0.8
N. Lines	1,024	2,048	4,096	8,192	16,384	32,768	49,152	91,200	-

1 - Calculated amplitude resolution is based on the accelerometer digital output in $\mu\text{g}/\text{LSB}$ or mg/LSB . 2 - Check the setting in the Spectral Monitoring Settings" table. 3 - Minimum RPM based on the longest measurement considering one full revolution of the shaft.

Quick Installation Guide

- Define the critical points of the machines to be monitored for the DynaLogger installation;
- It is only necessary to install one DynaLogger per monitoring point, because the devices are triaxial;
- Avoid installation in areas of the housings that present any stiffness loss. Example: cooling fins, covers, and protections. Try to install in rigid parts of the machine, preferably near the bearings;
- Align one of the axes of the DynaLogger with the actual axis of the machine. These axes are shown in the schematic to the side and on the body of the devices. A detailed installation guide can be found at Dynamox's [support website](#).

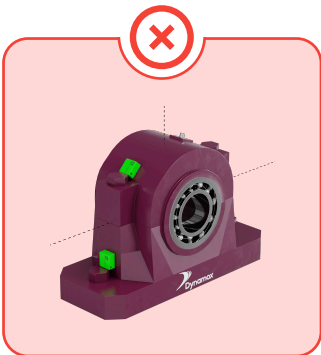
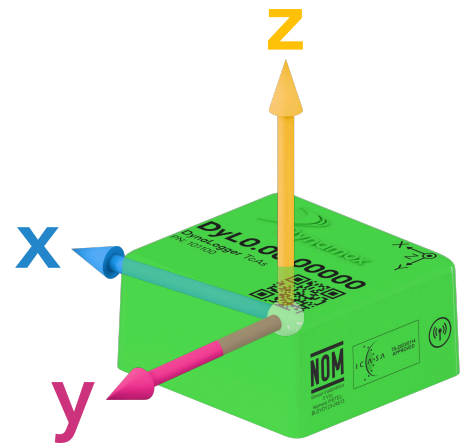

It is recommended to install the DynaLogger centrally on the component.

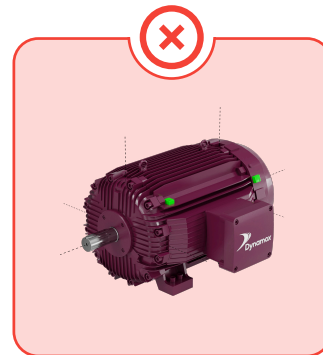
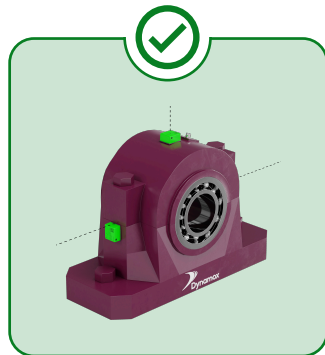

Installation on cooling fins and covers is not recommended.



Note: For motors, the recommendation is to install a sensor on the drive side (DS) and another one on the non-drive side (NDS) for complete monitoring.

Regarding the types of mounting, the TcAs DynaLogger can be:

Glued: After cleaning the site, apply adhesive glue to cover the entire sensor base. The adhesives DP8810, DP8710, DP420, DP-420NS and DP-8407NS from 3M, and the adhesive HY4090 from Loctite are approved by Dynamox for use with the sensor.

Technical Drawing

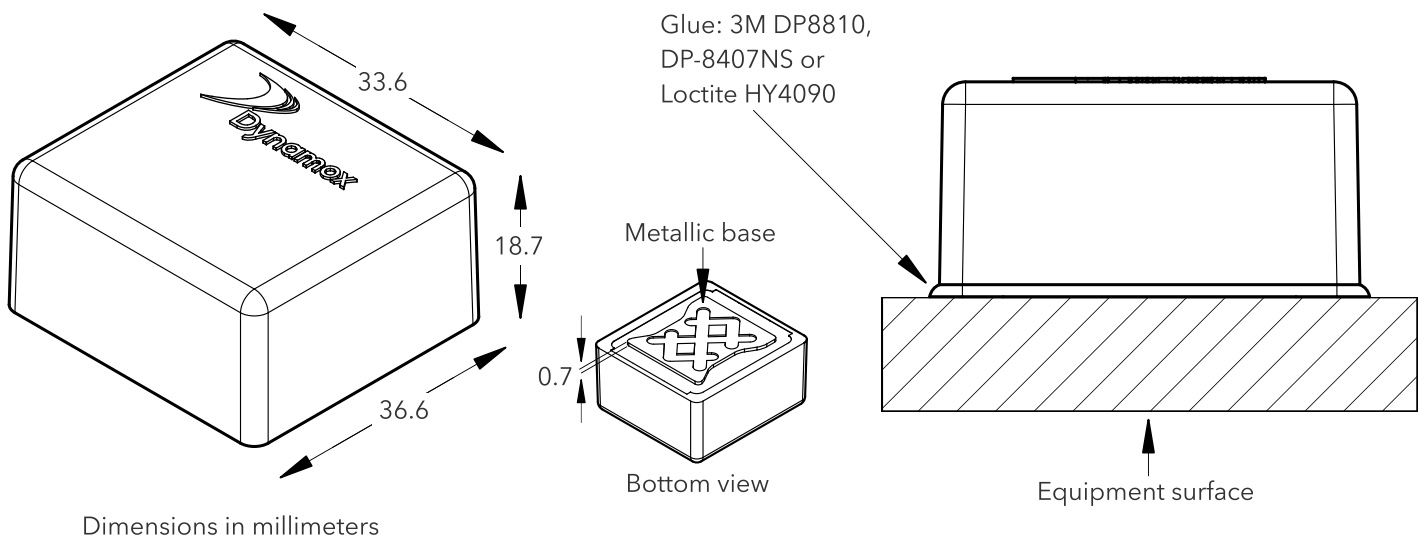

Dimensions in millimeters

Bottom view

Equipment surface

CERTIFICATION

Homologation/Certification	ANATEL/CE/ACMA/FCC/IC/INMETRO/IECEX/ATEX
Explosive Atmosphere	<p>IECEX/ATEX/INMETRO (batches \geq 06):</p> <ul style="list-style-type: none"> • Ex ia IIC T4 Ga • Ex ia IIIC T88°C Da • IP66/IP68/IP69K <p>INMETRO (batches $<$ 06):</p> <ul style="list-style-type: none"> • Ex ma IIC T6 Ga • Ex ta IIIC T85 °C Da • IP66/IP68/IP69

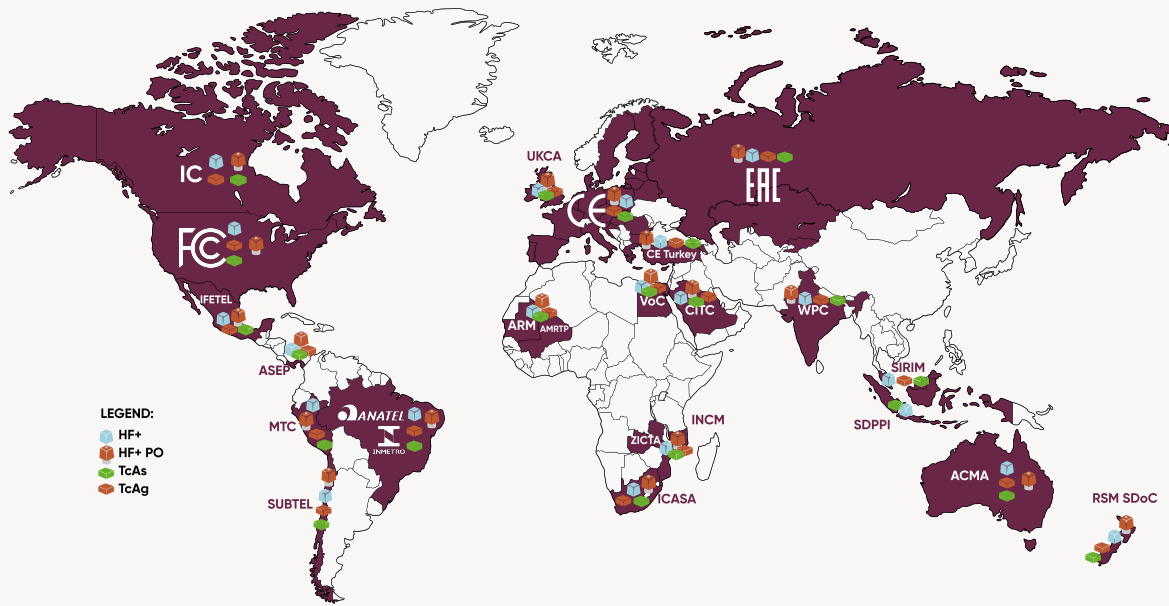

For more information about certifications, contact our technical support at: www.dynamox.net/contact-us

© 2025, Dynamox® is a registered trademark.
All rights reserved.

The contents of this publication are presented for information purposes only. Every care has been taken to ensure the validity of the information contained in this publication, but no liability can be assumed for any loss or damage whether direct, indirect or arising from the use of the information contained herein. We reserve the right to modify or improve the specifications of our products at any time without prior notice.



Get in touch:
www.dynamox.net/contact-us