

Piezo element products group

● Bimorph type vibrators

Bimorph type vibrator has bonded the two piezoceramic elements. If one element is extends in the longitudinal direction, the other elements are configured to compressed. This will be the flexural vibrators. Conversely, when apply flexural force outputs an electric field corresponding to the force. Many, it has a natural frequency of the auditory area. For this reason, it is used as a highly sensitive sound sensors or bending actuator of ON-OFF drives,.

Typical Applications

- Diaphragm micro pumps
- Sound pickups
- Vibration switch
- Bone conduction microphones
- Passage flapper valve
- Various actuators



for Actuators



for Sensors

Basic structures

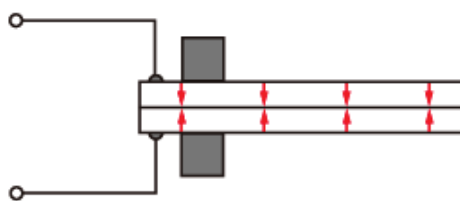

Series type

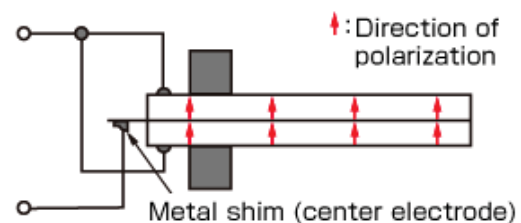

Parallel type

Bimorph type vibrator, by the connection method, can be divided into series type and the parallel type. Many that's used as the actuator is parallel type. The actuator is a challenge to obtain a large displacement at a low voltage. The amount of displacement of the actuator is proportional to the applied voltage per unit thickness of the piezoelectric elements. If the voltage and dimensions are the same, a larger parallel type of internal electric field, large displacement can be obtained. Also, in the series type, output voltage and internal impedance is larger than the parallel type. The output voltage is twice, internal impedance is fourfold. Therefore, the series type is used for high sensitive sensing of faint signal.

Fabrication range

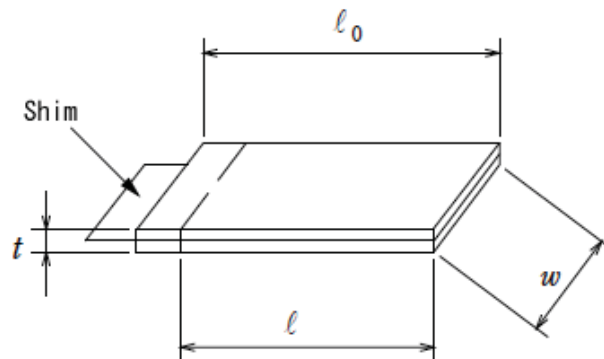

The thickness t_s of the shim (elastic stiffening plate) is 0.05mm and 0.1mm standard. Free length l of one end fixed, is about 85% of the total length l_0 is standard. Length l_0 , width w and thickness t , the fabrications range is shown below.

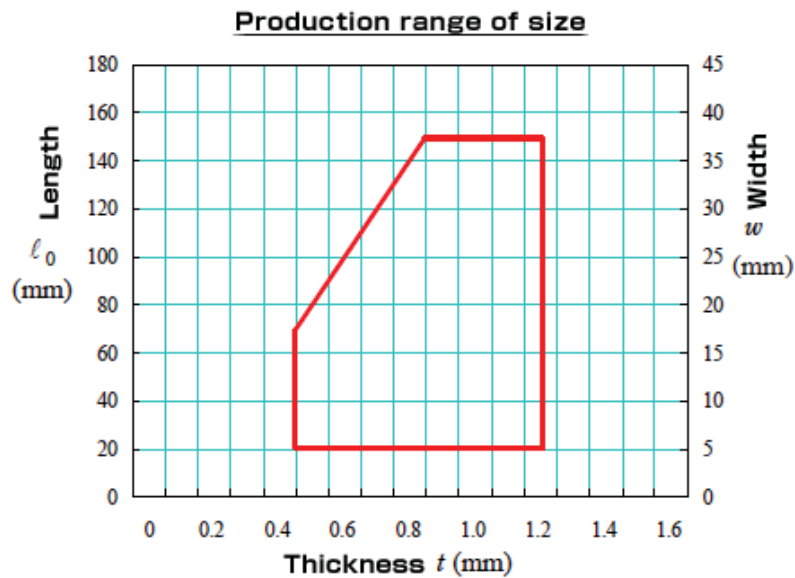

Bimorph type actuator is compared to the multilayer actuator, the generative force is small, but the amount of displacement is large. Therefore, it is suitable for micromotion actuator of small types. Also, bimorph type actuator is electrically and mechanically positive and negative symmetry. For this purpose, displacement, generated force will draw a symmetrical hysteresis curve with respect to the applied voltage.

Bimorph type vibrator's relational expression

Conditions	One end fixed		Supporting both ends	
	Series type	Parallel type	Series type	Parallel type
Generating charge amounts	$Q_{cs} = \frac{3}{2} d_{31} \left(\frac{\ell}{t}\right)^2 F$	$Q_{cp} = 3d_{31} \left(\frac{\ell}{t}\right)^2 F$	$Q_{ss} = \frac{3}{8} d_{31} \left(\frac{\ell}{t}\right)^2 F$	$Q_{sp} = \frac{3}{4} d_{31} \left(\frac{\ell}{t}\right)^2 F$
Output voltage versus forces F	$V_s = \frac{3}{2} g_{31} \frac{\ell}{tw} F$	$V_p = \frac{3}{4} g_{31} \frac{\ell}{tw} F$	$V_s = \frac{3}{8} g_{31} \frac{\ell}{tw} F$	$V_p = \frac{3}{16} g_{31} \frac{\ell}{tw} F$
Output voltage versus displacement	$V_s = \frac{3}{8} g_{31} Y \left(\frac{t}{\ell}\right)^2 u$	$V_p = \frac{3}{16} g_{31} Y \left(\frac{t}{\ell}\right)^2 u$	$V_s = \frac{3}{2} g_{31} Y \left(\frac{t}{\ell}\right)^2 u$	$V_p = \frac{3}{4} g_{31} Y \left(\frac{t}{\ell}\right)^2 u$
Capacitance	$C_{ds} = \epsilon_{33} \frac{T \ell w}{t}$	$C_{dp} = 4 \epsilon_{33} \frac{T \ell w}{t}$	$C_{ds} = \epsilon_{33} \frac{T \ell w}{t}$	$C_{dp} = 4 \epsilon_{33} \frac{T \ell w}{t}$
Compliance	$s_{nc} = \frac{1}{Y} \cdot \frac{4\ell^3}{w t^3}$		$s_{ns} = \frac{1}{4} \cdot \frac{1}{Y} \cdot \frac{\ell^3}{w t^3}$	
Displacement	$u_c = F \cdot s_{nc}$		$u_s = F \cdot s_{ns}$	
Resonant frequency	$f_{rs} = \frac{\alpha_n^2}{4\sqrt{3}\pi} \cdot \frac{t}{\ell^2} \cdot \sqrt{\frac{Y}{\rho}}$	$\alpha_1=1.875$ $\alpha_2=4.69$ $\alpha_3=7.85$	$f_{rs} = \frac{\alpha_n^2}{4\sqrt{3}\pi} \cdot \frac{t}{\ell^2} \cdot \sqrt{\frac{Y}{\rho}}$	$\alpha_1 = \pi$ $\alpha_3 = 3\pi$

Parallel type bimorph vibrators, when used with one end fixed, relationship between the displacement u_0 and the generated force F_b or compliances s_n and the resonant frequency f_{rm} is shown in the following formula.

$$u_0 = 3d_{31} \left(\frac{\ell}{t}\right)^2 \cdot \left(1 + \frac{t_s}{t}\right) \cdot V \cdot \alpha \quad [\text{mm}]$$

$$F_b = \frac{u_0}{s_n} \quad [\text{N}]$$

$$s_n = s_{11}^E \cdot \frac{4\ell^3}{wt^3} \quad [\text{m/N}]$$

$$f_{rm} = \frac{1.875^2}{4\sqrt{3}\pi} \cdot \frac{t}{\ell^2} \cdot \sqrt{\frac{Y_{11}^E}{\rho}} \quad [\text{Hz}]$$

{

- α : Nonlinearly correction coefficient (=2)
- d_{31} : Piezoelectric constant
(C-82: -266×10^{-12} [m/V])
- V : Applied voltage
- s_{11}^E : Elastic compliance of piezo (=1/ Y_{11}^E)
- Y_{11}^E : Young's modulus of piezo (=1/ s_{11}^E)
- t_s : Shim thickness (elastic reinforcing plate)
- ρ : Density of piezo (C-82: 7.5×10^3 [kg/m³])

Typical characteristics

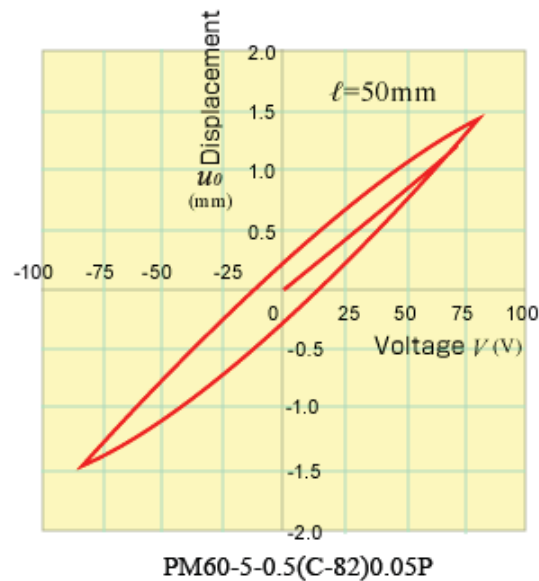

Displacement u_0 is proportional to the applied voltage V proportional to the square of the length l_0 . Generated force F is proportional to the applied voltage V proportional to the width w . Maximum applied DC voltage level V_{\max} of the normal temperature, please use within the range of the following formula.

$$V_{\max} = E_r \cdot \frac{t - t_s}{2} \quad (\text{V})$$

An example of endurance electric field E_r due to the material of the piezoelectric body is shown below.

C-6 : 400 [V/mm]

C-82 : 300 [V/mm]

C-91 : 250 [V/mm]

The actuator, in terms of half of the no-load displacement amount $u_0/2$, energy will be the maximum. And, by driving the load in the vicinity of that, it can use the most efficient. Energy of the actuators is determined by the width of the applied voltage and the actuators. The higher the applied voltage, energy will increase. However, there is a limit depending on the material of the piezoelectric body.