

TECHNICAL PARAMETERS Modal exciter S 51140-MOSP

Rated peak force Sine _{pk} /Random _{RMS} ¹	400/280 N
Frequency range	DC - 5000 Hz
Main resonance frequency (free-swinging)	4000 Hz
Max. displacement Peak-Peak	25.4 mm
Max. velocity	1.5 m/s
Suspension stiffness	4 N/mm
Effective moving mass	0.4 kg
Total mass	21 kg
Coupling thread	M6

¹) Random force according to ISO 5344:2004

For long-term tests, the load must be reduced to 80 %. Continuous operation at maximum load can cause damage.

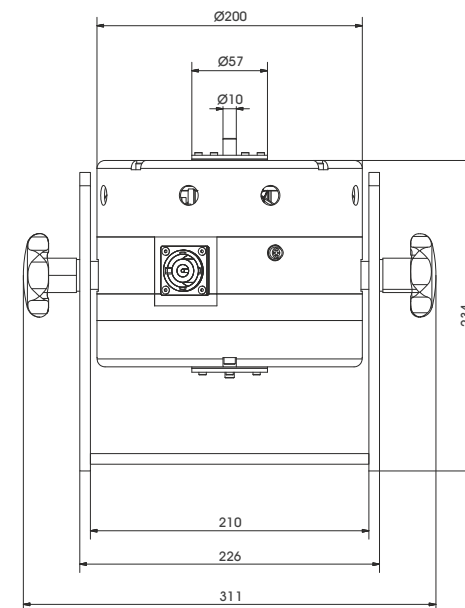

SCOPE OF DELIVERY, OPTIONS AND FEATURES OF THE SYSTEM

<p>Scope of delivery: Modal exciter 400 N Trunnion mount Power amplifier 1200 VA Cooling blower Connection cable (5 m) Power cable amplifier (1.5 m) Blower hose ø40 mm (3 m)</p>	<p>Options: Rack for mounting the amplifier Silencer for cooling blower (Noise reduction up to 8 dB(A)) Acoustic enclosure for cooling blower (Noise reduction 15 - 23 dB(A)) Stinger (see Modal brochure for details) Cable extension Factory acceptance test</p>	<p>Features: Vibration isolation Coarse filter unit High cross-axial stiffness Throughhole in the center of the armature for attaching tension-wire stingers Light weight construction by using rare earth magnet Minimum maintenance effort Made in Germany Servicehotline</p>
---	---	--

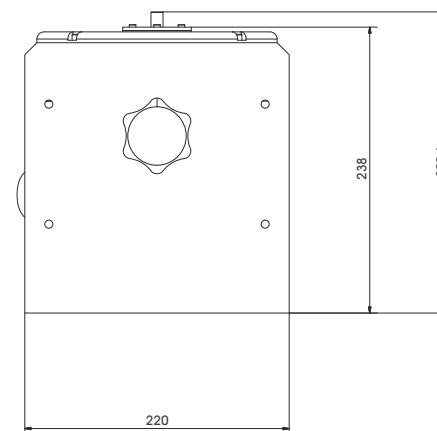

TECHNICAL PARAMETERS Amplifier BAA 1000

Output power _{RMS}	1200 VA
Frequency range	DC - 20 kHz
Voltage-/Current mode	yes/yes
Voltage _{RMS} max.	72 V
Current _{RMS} max.	18 A
Signal input voltage _{RMS}	< 5 V
Distortion	< 0.1 %
Signal to noise ratio	> 90 dB
Total mass	35 kg
Dimensions (WxHxD)	483 x 146 x 585 mm
Power supply (Standard)	1 ~ / N / PE 230 V ± 5% 50 Hz, CEE 7/7
Recommended fuse protection (Standard)	16 A slow
Max. power consumption at 230 V	2.7 kVA
Interlocks:	Overload, temperature, clipping and more

Features:
High Signal to noise ratio of >90 dB

TECHNICAL PARAMETERS Cooling blower TB 0140

Volume flow rate	max. 140 m ³ /h
Total pressure difference	max. 150 mbar
Power	1.1 kW
Frequency	50 Hz
Hose diameter	40 mm
Hose length (Std.)	3 m
Total mass	16 kg
Dimensions (WxHxD)	286 x 302 x 292 mm
Sound pressure level, max.	max. 63 dB(A)
Power supply (Standard)	1 ~ / N / PE 230 V ± 5% 50 Hz, CEE 7/7
Max. current consumption at 400 V	7.3 A

Options:
 Silencer (Noise reduction up to 8 dB(A))
 Dimensions (LxD): 308 x 82 mm
 Mass: 0.2 kg
 Acoustic enclosure (Noise reduction 15 - 23 dB(A))
 Dimensions (WxHxD): 860 x 760 x 650 mm
 Mass: 45 kg
 Hose length according to customers request (up to 10 m)

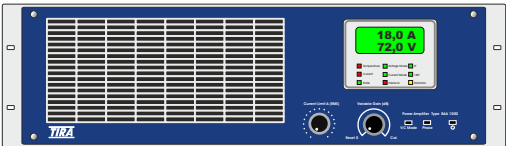

Cooling blower TB 0140



Silencer TB 0140-SI (optional)



Acoustic enclosure TB 0140-AE (optional)