

TECHNICAL PARAMETERS Vibration exciter S 51120

Rated peak force Sine _{pk} /Random _{RMS} ¹	200/140 N
Frequency range	2-7000 Hz
Main resonance frequency	>6500 Hz
Max. displacement Peak-Peak ²	13 mm
Max. velocity	1.5 m/s
Max. acceleration Sine/Random	89/62 g
Suspension stiffness	8 N/mm
Effective moving mass	0.23 kg
Total mass	12 kg
Armature diameter	60 mm

1) Random force according to ISO 5344:2004
2) Payload has an impact on the possible maximum displacement

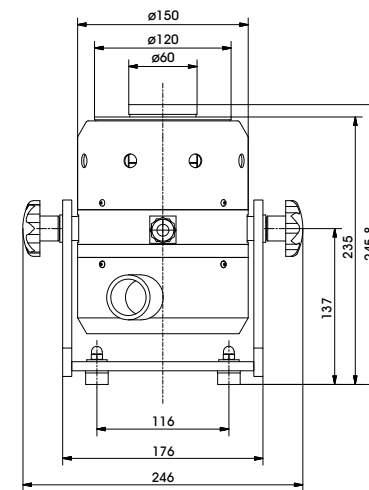

SCOPE OF DELIVERY, OPTIONS AND FEATURES OF THE SYSTEM

<p>Scope of delivery: Vibration exciter 200 N Trunnion mount Power amplifier 500 VA Cooling blower Connection cable (3 m) Power cable amplifier (1.5 m) Blower hose ø40 mm (3 m)</p>	<p>Options: Rack for mounting the amplifier Silencer for cooling blower (Noise reduction up to 5 dB(A)) Acoustic enclosure for cooling blower (Noise reduction 15 - 23 dB(A)) Modal adapter M6 Stinger (see Modal brochure for details) Cable extension Factory acceptance test</p>	<p>Features: Vibration isolation Coarse filter unit High cross-axial stiffness Lightweight construction by using rare earth magnet Minimum maintenance effort Made in Germany Servicehotline</p>
--	---	--

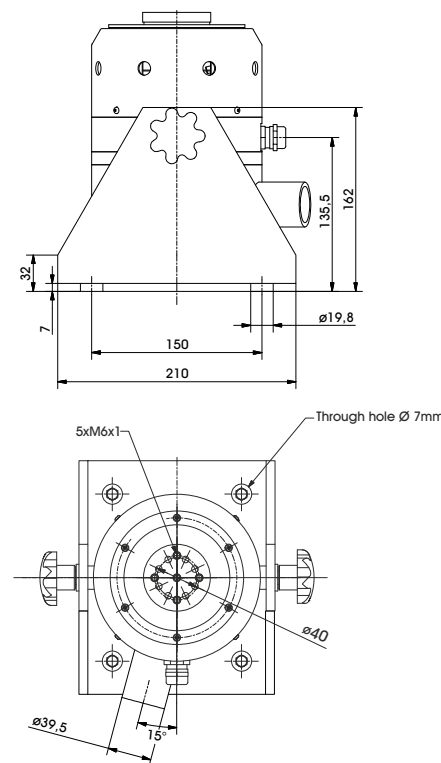

TECHNICAL PARAMETERS Amplifier BAA 500

Output power _{RMS}	500 VA
Frequency range	DC - 20 kHz
Voltage-/Current mode	yes/yes
Voltage _{RMS} max	45 V
Current _{RMS} max. (below 5 Hz)	11.2 A (5 A)
Signal input voltage _{RMS}	< 5 V
Distortion	< 0.1 %
Signal to noise ratio	> 110 dB
Total mass	18 kg
Dimensions (WxHxD)	440 x 90 x 290 mm
Power supply (Standard)	1 ~ / N / PE 230 V±5% 50 Hz, CEE 7/7
Recommended fuse protection (Standard)	16 A slow
Max. power consumption at 230 V	0.35 kVA
Interlocks:	Overload, temperature, clipping and more

Features:
High Signal to noise ratio of > 110 dB

TECHNICAL PARAMETERS Cooling blower TB 0080

Volume flow rate	max. 80 m³/h
Total pressure difference	max. 120 hPa
Power	0.37 kW
Frequency	50 Hz
Hose diameter	40 mm
Hose length (Std.)	3 m
Total mass	10 kg
Dimensions (WxHxD)	246 x 256 x 247 mm
Sound pressure level, max.	max. 53 dB(A)
Power supply (standard)	1 ~ / N / PE 230 V±5% 50 Hz, CEE 7/7
Max. current consumption at 230 V	2.7 A

Options:
 Silencer TB 0080-SI (Noise reduction up to 5 dB(A))
 Dimensions (LxD): 310 x 65 mm
 Mass: 0.2 kg
 Acoustic enclosure TB 0080-AE (Noise reduction 15 - 23 dB(A))
 Dimensions (WxHxD): 860 x 760 x 650 mm
 Mass: 45 kg
 Hose length according to customers request (up to 10 m)

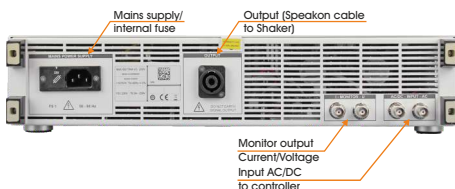

Cooling blower TB 0080



Silencer TB 0080-SI (optional)



Acoustic enclosure TB 0080-AE (optional)