

TECHNICAL PARAMETERS Vibration exciter S 57315/LS-340

Rated peak force Sine _{pk} /Random _{RMS} ¹ /Shock _{pk} ²	15000/13000/45000 N
Frequency range	2 - 3000 Hz
Main resonance frequency	>2400 Hz
Max. displacement Peak-Peak	50.8 mm
Max. velocity Sine/Random/Shock	2.0/2.0/3.5 m/s
Max. acceleration Sine/Random/Shock	110/80/200 g
Suspension stiffness	75 N/mm
Effective moving mass (±5%)	13.5 kg
Max. payload	250 kg
Total mass	1100 kg
Magn. stray field Std./low degaussing ³	<1.5/<0.8 mT
Armature diameter	340 mm
Min. required compressed air supply	600 kPa
Interlocks	Field coil temperature, displacement, cooling air, overcurrent, compressed air

1) Random force according to ISO 5344:2004

2) Theoretical maximum shock value. Depends on payload, amplifier, shock and shock width

3) measured at 150 mm above armature

For long-term tests, the load must be reduced to 80 %. Continuous operation at maximum load can cause damage.

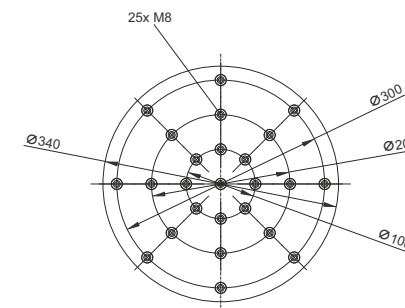
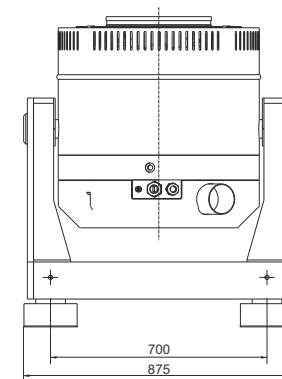
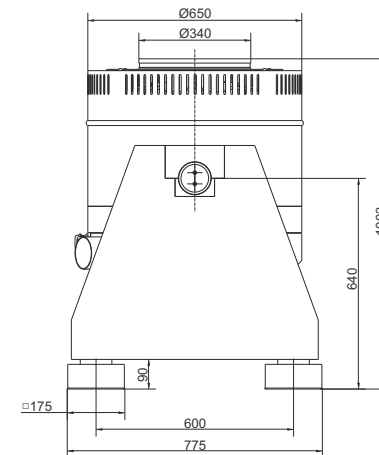

Armature 340 (Standard)

SCOPE OF DELIVERY, OPTIONS AND FEATURES OF THE SYSTEM

Scope of delivery:

- Vibration exciter 15 kN
- Trunnion mount
- Power amplifier 22.5 kVA
- Cooling blower
- Connection cable (5 m)
- Power cable (5 m)
for amplifier (CEE 63 connector)
- Blower hose Ø140 mm (5 m)
- Compressed-air hose NW 7,2
(Standard) (3 m)

Options:

- Different thread inserts in the armature
at customer request
- Low degaussing kit
to further reduce stray magnetic field
- Squeak&Rattle (Silent operation without blower)
- Wheels&Rails (incl. 3m rails)
- Thermobarrier (-40°C to +140°C)
- Chamber leadthrough
- Climatic chamber support kit
- Remote control (Software)
- Silencer
for cooling blower (Noise reduction 3 - 6 dB(A))
- Acoustic enclosure
for cooling blower (Noise reduction 5 - 23 dB(A))
- Cable extension
- Factory acceptance test

Options:

TIRA EMS Energy Management System

- Operation with temperature-controlled
cooling blower (and optional with
variable field strength)
- ASM-Mode (Auto Shutdown Manager)

Features:

- Vibration isolation < 6 Hz
- Coarse filter unit
- Fully automatic pneumatic
load compensation
- Automatic centering of the armature
- Degauss kit to reduce stray magnetic field
- Made in Germany
- Servicehotline

TECHNICAL PARAMETERS Amplifier A 3 01 11 042

Output power _{RMS}	22500 VA
Frequency range	DC - 5 kHz
Voltage _{RMS} , max.	±212 V
Current _{RMS} , max.	200 A
Signal input voltage	10 V
Total Harmonic Distortion (at 70A _{RMS} , 200 Hz)	< 0.2 %
Signal to noise ratio	> 80 dB
Field voltage	140 V
Field current	8 A
Total mass	450 kg
Dimensions (WxHxD)	600 x 2200 x 800 mm
Power supply (Standard)	3~ / N / PE 400 V±5% 50 Hz, CEE 63
Recommended fuse protection (Standard)	63 A slow
Max. power consumption at 400 V (incl. blower)	23.5 kVA
Interlocks:	Overload, Temperature, Displacement, Cooling air, Compressed air, Phase monitoring, Emergency stop

Features:

- Field supply integrated
- Mains switch and integrated line filter
- Field voltage/Field current variable according to customer spec.
- 4 Sigma peak current
- Color Touch Screen



TECHNICAL PARAMETERS Cooling blower TB 120 FUK

Max. volume flow rate	1500 m³/h
Total pressure difference	10.2 kPa
Motor output	5.5 kW
Max. frequency	100 Hz
Hose diameter	140 mm
Hose length (Std.)	5 m
Total mass	61 kg
Dimensions (WxHxD)	487 x 637 x 487 mm
Max. sound pressure level	102 dB(A)
Power supply (standard)	by amplifier rack
Max. current consumption at 400 V	12 A

Options:

- Silencer TB 120-SI (Noise reduction 3 - 6 dB(A))
Dimensions (LxD): 1100 x 160 mm
Mass: 1.2 kg
- Acoustic enclosure TB 120-AE (Noise reduction 5 - 23 dB(A))
Dimensions (WxHxD): 1250 x 1393 x 1470 mm
Mass: 103 kg
- Hose length according to customers request (up to 10 m)

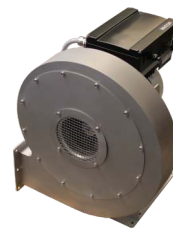

Cooling blower TB 120 FUK



Silencer TB 120-SI (optional)



Acoustic enclosure TB 120-AE (optional)