

**TECHNICAL PARAMETERS**

Rated peak force Sine <sub>pk</sub> /Random <sub>RMS</sub> <sup>1</sup> /Shock <sub>pk</sub> <sup>2</sup>	70000/67000/210000 N
Frequency range	5 - 2500 Hz
Main resonance frequency	> 2100 Hz
Max. displacement Pk-Pk Sine/Random/Shock <sup>3</sup>	63.5/63.5/76.2 mm
Max. velocity Sine/Random/Shock	2.0/2.0/3.5 m/s
Max. acceleration Sine/Random/Shock	100/80/350 g
Suspension stiffness	250 N/mm
Effective moving mass	70 kg
Max. payload	910 kg
Magn. stray field <sup>4</sup>	1.5 mT
Armature diameter	480 mm
Min. required compressed air supply	600 kPa
Total mass	4800 kg
Interlocks	Temperature, displacement, cooling air, overcurrent, compressed air

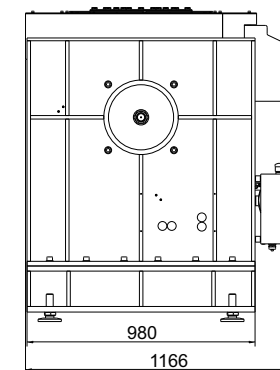
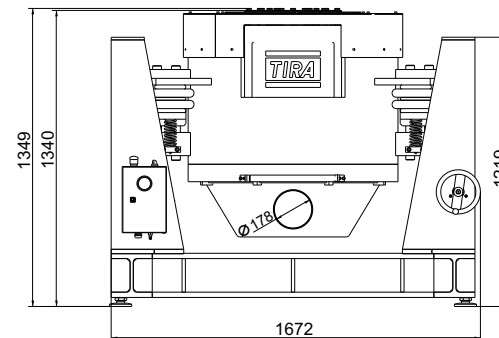

1) Random force vector according to ISO 5344  
 2) Theoretical maximum shock value. Depends on payload, amplifier, shock and shock width  
 3) Impact by moving to static mass and frequency is possible  
 4) measured at 150 mm above armature inserts

For long-term tests, the load must be reduced to 80 %. Continuous operation at maximum load can cause damage.

**SCOPE OF DELIVERY, OPTIONS AND FEATURES OF THE SYSTEM**

**Scope of delivery:**  
 Vibration exciter  
 Trunnion mount  
 with integrated vibration isolation (AIT)  
 Power amplifier  
 Cooling blower  
 Connection box for blower  
 Connection cables (each 10 m)  
 Power cable (10 m)  
 for cooling blower (CEE 63 connector)  
 Blower hose Ø175 mm (5 m)  
 Compressed-air hose NW 7,2 (Standard) (5 m)

**Options:**  
 Different hole pattern of armature (different pitch diameter and/or thread inserts) at customers request  
 Airglide-option (Shaker movable on air cushions)  
 Squeak&Rattle (Silent operation without blower)  
 Thermobarrier (-40°C to +140°C)  
 Chamber leadthrough  
 Climatic chamber support kit  
 Remote control (Software)  
 ASM-Mode (Auto Shutdown Manager)  
 Silencer  
 for cooling blower (Noise reduction 9 - 15 dB(A))  
 Acoustic enclosure  
 for cooling blower (Noise reduction 5 - 23 dB(A))  
 Water-cooled acoustic enclosure  
 for cooling blower (Noise reduction 30 dB(A))  
 Cable extension  
 Factory acceptance test

**Options:**  
**TIRA EMS** Energy Management System

Operation with temperature-controlled cooling blower (and optional with variable field strength)

**Features:**  
 AIT-trunnion with integrated vibration isolation < 3 Hz  
 Coarse filter unit  
 Fully automatic pneumatic load compensation  
 AIT fixable  
 Automatic centering of the AIT-System and the armature  
 Degauss kit to reduce stray magnetic field  
 Made in Germany  
 Servicehotline

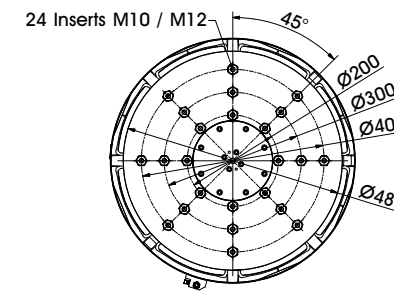

Armature 480 (Standard)

## TECHNICAL PARAMETERS Amplifier A 6 26 11 147

Output power <sub>RMS</sub>	90000 VA
Frequency range	DC - 5 kHz
Voltage <sub>RMS</sub> , max.	±212 V
Current <sub>RMS</sub> , max.	700 A
Signal input voltage <sub>RMS</sub>	10 V
Total Harmonic Distortion	< 0.2 %
Signal to noise ratio	> 80 dB
Field voltage	250 V
Field current	103 A
Power supply (Standard)	3~ / N / PE 400 V±5% 50 Hz
	Direct connection (Terminal block)
Max. power consumption at 400 V	82 kVA
Recommended fuse protection (Standard)	125 A slow
Dimensions (WxHxD)	1800 x 2200 x 900 mm
Total mass	1150 kg
Interlocks:	Overload, Temperature, Displacement, Cooling air, Compressed air, Phase monitoring, Emergency stop

### Features:

- Field supply integrated
- Mains switch and integrated line filter
- Lo-Field/Hi-Field (Energy-saving mode)
- Field voltage/Field current variable according to customer spec.
- 4 Sigma peak current
- Color Touch Screen

## TECHNICAL PARAMETERS Cooling blower TB HR160

Max. volume flow rate	6600 m³/h
Max. total pressure increase	17 kPa
Rated motor output	25 kW
Rated frequency	88 Hz
Hose diameter	175 mm
Hose length (Std.)	5 m
Max. sound pressure level	105 dB(A)
Dimensions (WxHxD)	672 x 760 x 730 mm
Total mass	97.5 kg
Connection box (fixation to wall):	
Power supply (Standard)	3~ / PE 400 V±5% 50 Hz CEE 63
Max.current consumption at 400 V	42 A
Recommended fuse protection (Standard)	50 A slow
Dimensions (WxHxD)	300 x 300 x 250 mm
Mass	10 kg

### Options:

- Silencer TB HR160-SI (Noise reduction 9 - 15 dB(A))
  - Dimensions (LxD): 1120 x 280 mm
  - Mass: 9.2 kg
- Acoustic enclosure TB HR160-AE (Noise reduction 5 - 23 dB(A))
  - Dimensions (WxHxD): 1250 x 1393 x 1470 mm
  - Mass: 103 kg
- Water-cooled acoustic enclosure WWT (Noise reduction 30 dB(A))
  - Dimensions (WxHxD): 1500 x 2080 x 1200 mm
  - Mass: 800 kg
- Hose length according to customers request (up to 10 m)



Amplifier (illustration similar)



Connection box with main switch (for blower)



Cooling blower TB HR160



Silencer TB HR160-SI (optional)



Acoustic enclosure TB HR160-AE (optional)