

OPERATING MANUAL

SmartBox-8CH

Smart Sensor Hub

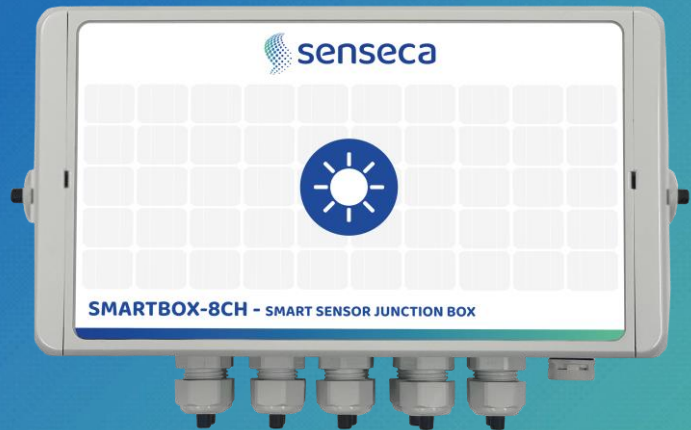

EN

V1.0



Contents

1	Introduction	3
2	Technical Specifications	4
3	Installation.....	5
3.1	Elements on electronics	6
3.2	Electrical connections	7
3.3	RS-485 bus termination resistor.....	9
4	Maintenance	10

1 Introduction

The SmartBox-8CH Smart Sensor Hub has been designed to simplify, and reduce the installation costs of a complete measurement system based on smart sensors and a datalogger. It is specifically engineered for sites where considerable distances between sensors would traditionally require extensive and costly cabling.

This device allows for the deployment of a single RS-485 bus throughout the entire installation, replacing the need for complex wiring infrastructures. By connecting various SmartBox-8CH along this bus, the system supports the interconnection of a wide range of devices, including:

- Modbus sensors: Any sensor utilizing the Modbus RTU protocol. E.g. pyranometers and albedometers.
- Analog interfaces: Such as PT100 and PT1000 using Modbus conversion.
- General Smart Sensors: Any sensor using a smart protocol.

The SmartBox-8CH brings the following benefits to the monitoring systems installation:

- **Optimized topology:** significantly reduces the need for long cable runs between the station and sensors by moving away from traditional "Star" installation topologies.
- **Signal Integrity & Extension:** capable of isolating sections of the field bus and extending the maximum operable cable length.
- **Power Integration:** optionally allows the integration of additional power supplies into the system installation.

'STAR' TOPOLOGY WITHOUT SB-8CH:

- Complex layout and wasteful cable usage
- Signal reflections and noise
- Low reliability
- Ground loops / high exposition to damage due to ESD

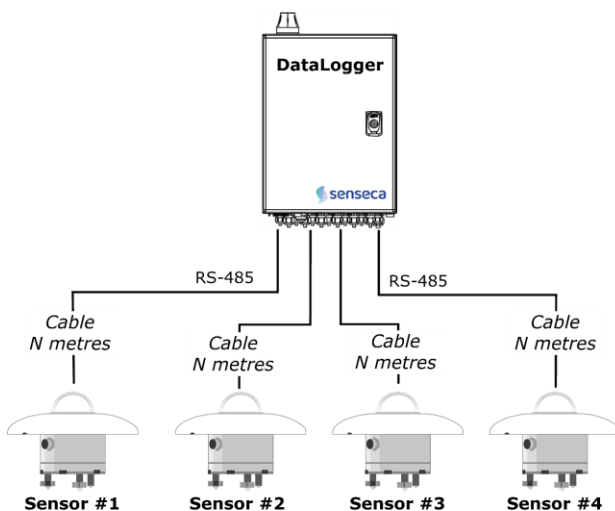

TOPOLOGY INCLUDING A SB-8CH:

- Simplified and efficient cable routing
- Enhanced signal integrity
- Robust communication
- ESD protection for interconnected devices

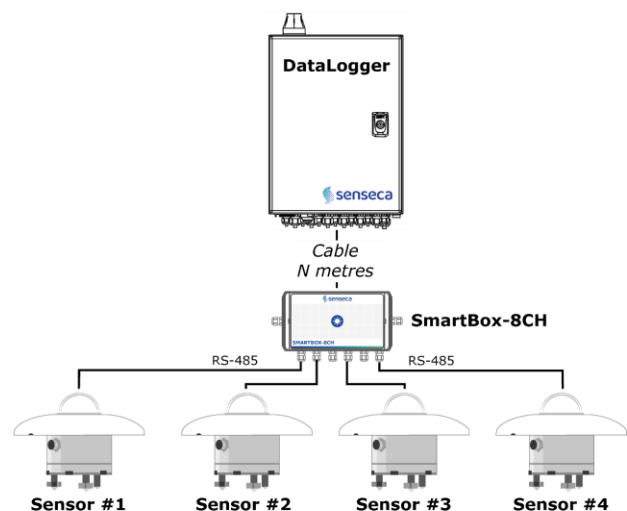

Fig. 1.1: Advantages of installation architectures with SmartBox-8CH

2 Technical Specifications

Communication bus	RS-485 / Modbus RTU
No. of sensors	Up to 8 Modbus sensors (fast response) or 4 (standard response) Up to 3 Modbus sensors + 1 Extension Module with 5 additional analog sensors connected
Protection Rating	Enclosure IP68 / IP66 cable gland Pressure compensator included
Enclosure material	Polycarbonate UL-94 V0 (fire-retardant and self-extinguishing and UV resistant)
Outer dimensions	200 x 160 x 90 mm
Accessories	Mast and wall fixings, made from 6060 anodized aluminum

The SmartBox -8CH is adaptable to diverse site conditions via multiple model variants. The appropriate model selection depends on the distance to the datalogger, the type and quantity of sensors connected to each box, and the specific optical isolation needs of the installation.

Variant	SB-8CH-1 (Type 1)	SB-8CH-2 (Type 2)	SB-8CH-3 (Type 3)	SB-8CH-4 (Type 4)
		Passive, without isolation	Active, without isolation	Active, with isolation
Distance	< 25 m	< 100 m	> 100 m	< 5 Km LoS
Max. power consumption for sensors	3 W	20 W		
Power supply	-	20 W 15/24 VDC		
Power grid	-	85 - 305 VAC		
Isolation	-	-	Optical up to 3KVDC	-
Protections	IEC-61000-4-5 level 3: Surge immunity			
	IEC-61643-11 and EC-61643-41 (Class 2)			
	-	Power Supply protections: Overload / Overcharge		
Operating temperature	-40 °C to +85 °C			
	-	Power Supply: -30 to +70°C		

3 Installation

The SmartBox installation process depends on the variant, which is selected at the time of ordering. This information is also available on the label attached to the inside of the box along with the internal elements included:

SMARTBOX-8CH - INTERNAL ELEMENTS:				
	Passive Non-Insulated	Active Non-Insulated	Active Insulated	Active with Radio
	TYPE1	TYPE2	TYPE3	TYPE4
P.S.U1 Mounted: SmartBox to Mains (P3) PHASE NEUTRAL EARTH	<input type="checkbox"/> Yes <input type="checkbox"/> No	<input type="checkbox"/> Yes <input type="checkbox"/> No	<input type="checkbox"/> Yes <input type="checkbox"/> No	<input type="checkbox"/> Yes <input type="checkbox"/> No
Model of P.S. U1 Mounted: (15VOUT or 24VOUT)	<input type="checkbox"/> 15V <input type="checkbox"/> 24V	<input type="checkbox"/> 15V <input type="checkbox"/> 24V	<input type="checkbox"/> 15V <input type="checkbox"/> 24V	<input type="checkbox"/> 15V <input type="checkbox"/> 24V
Power Supply from MTD: (P1) PWR-IN, GND, EARTH	<input type="checkbox"/> Yes <input type="checkbox"/> No	<input type="checkbox"/> Yes <input type="checkbox"/> No	<input type="checkbox"/> Yes <input type="checkbox"/> No	<input type="checkbox"/> Yes <input type="checkbox"/> No
M1 RS-485 Isolator Mounted: (U2) B-AIS, A-AIS, B-PROT, A-PROT	<input type="checkbox"/> Yes <input type="checkbox"/> No	<input type="checkbox"/> Yes <input type="checkbox"/> No	<input type="checkbox"/> Yes <input type="checkbox"/> No	<input type="checkbox"/> Yes <input type="checkbox"/> No
Jumpers at Isolator terminals: (U2) B-AIS with B-PROT, A-AIS with A-PROT	<input type="checkbox"/> Yes <input type="checkbox"/> No	<input type="checkbox"/> Yes <input type="checkbox"/> No	<input type="checkbox"/> Yes <input type="checkbox"/> No	<input type="checkbox"/> Yes <input type="checkbox"/> No
Termination R. (Last & dist.>200m): (P6) ACT_TERM-IN (P8) ACT_TERM-OUT	<input type="checkbox"/> Yes <input type="checkbox"/> No	<input type="checkbox"/> Yes <input type="checkbox"/> No	<input type="checkbox"/> Yes <input type="checkbox"/> No	<input type="checkbox"/> Yes <input type="checkbox"/> No
Jumper GND-EARTH: (P4)	<input type="checkbox"/> Yes <input type="checkbox"/> No	<input type="checkbox"/> Yes <input type="checkbox"/> No	<input type="checkbox"/> Yes <input type="checkbox"/> No	<input type="checkbox"/> Yes <input type="checkbox"/> No
Jumper ACT_EARTH-OUT: (P15)	<input type="checkbox"/> Yes <input type="checkbox"/> No	<input type="checkbox"/> Yes <input type="checkbox"/> No	<input type="checkbox"/> Yes <input type="checkbox"/> No	<input type="checkbox"/> Yes <input type="checkbox"/> No
Distance to MTD-4000: (or to Active SmartBox-8CH)	<25m <input type="checkbox"/>	<100m <input type="checkbox"/>	>100m <input type="checkbox"/>	<5Km <input type="checkbox"/>
Power Consumption of Connected Sensors:	<3W <input type="checkbox"/>	<20W <input type="checkbox"/>	<20W <input type="checkbox"/>	<20W <input type="checkbox"/>

WARNING! The SMARTBOX-8CH must be connected to the local EARTH (<5 Ω)

Fig. 3.1: SmartBox-8CH variant and elements information label

The cable run between the SmartBox and the datalogger must not exceed the maximum distance defined for the specific variant. Please refer to the specifications section for the limits applicable to each model.

The SmartBox-8CH installation kit is compatible with installation on panels, towers, masts or walls, as well as on the solar tracker’s power transmission shaft.

⚠ Warning!

Proper grounding is essential for the SmartBox-8CH’s built-in protections to function effectively and safeguard the bus components (sensors, datalogger, etc.) during discharge events. Grounding requirements vary by model; please refer to this section for further details.

To simplify installation and maintenance, every SmartBox includes a connections label. This label records the devices connected to its input and outputs, as well as the specific terminals used. When the SmartBox is supplied as part of a complete measurement system, this information is pre-filled at the factory to simplify the installation process at the site.

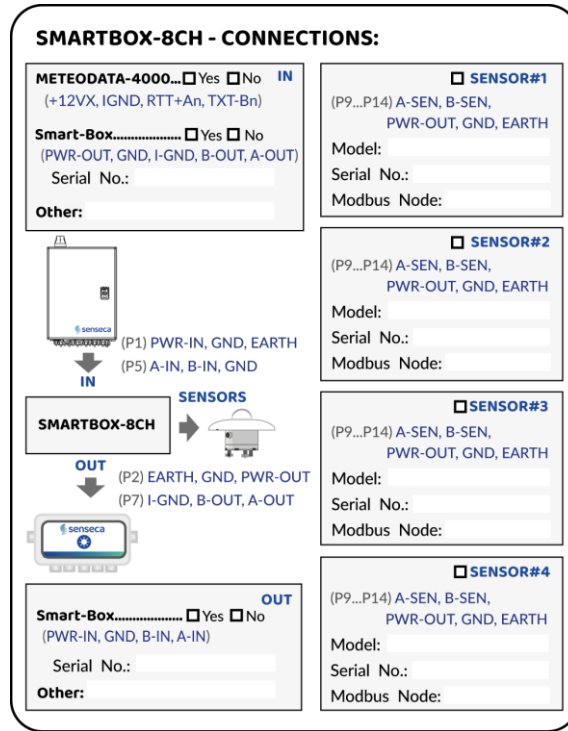

Fig. 3.2: SmartBox-8CH connections register label

Depending on site requirements, one or multiple SmartBox units are required per RS-485 bus. In daisy-chain configurations (multiple SmartBox units per line), the OUT gland (P2) is used to connect the signals to the subsequent SmartBox unit.

3.1 Elements on electronics

The following scheme and table describe the main parts of the SmartBox circuit board that will be mentioned along the following sections of this manual:

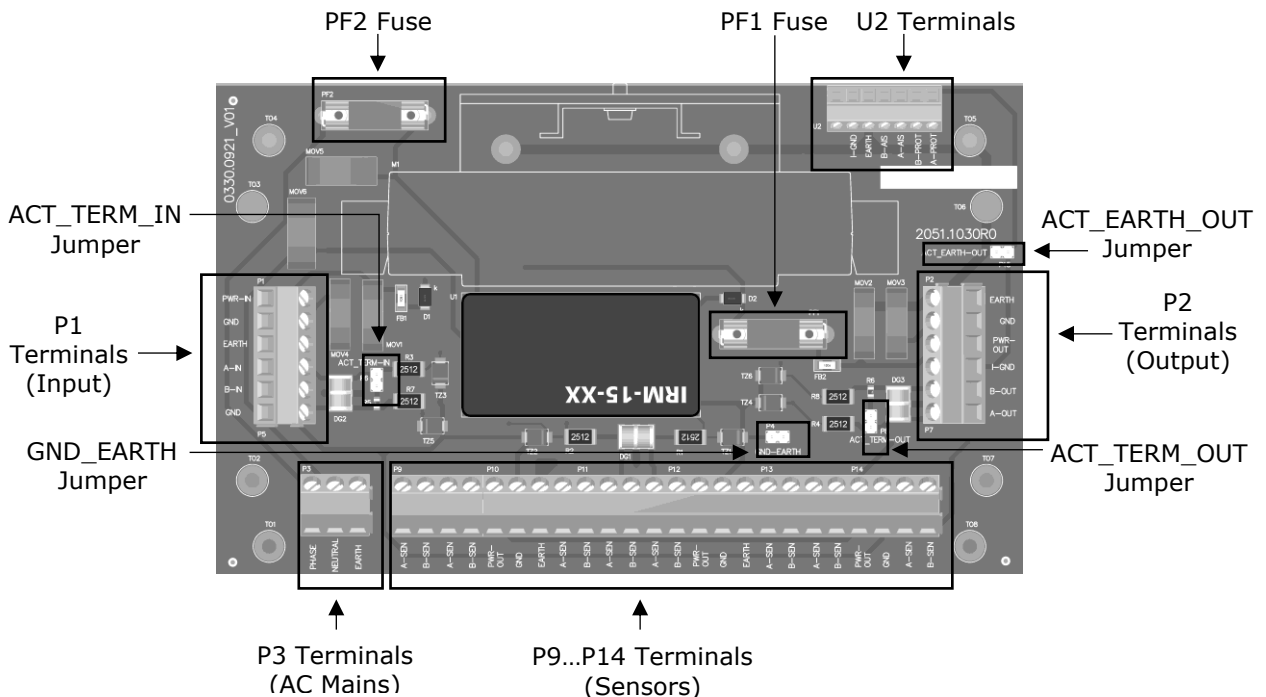

Fig. 3.3: SmartBox circuit board

3.2 Electrical connections

SB-8CH-1: Passive, without isolation

The datalogger's power supply is used to power the sensors connected to the SmartBox:

- The cable from the logger to the SB-8CH-1 includes both RS-485 signals and the power lines.
- The SmartBox is grounded through the datalogger's earthing connection.
- Since the sensors are powered by the logger's power supply, the distance between the logger and the SB-8CH-1 is limited to 25 m, and the total power consumption of all connected sensors must not exceed 3 W.

Warning!

The cable connecting the datalogger to the SB-8CH-1 includes power lines. Ensure the datalogger is powered off during wiring tasks.

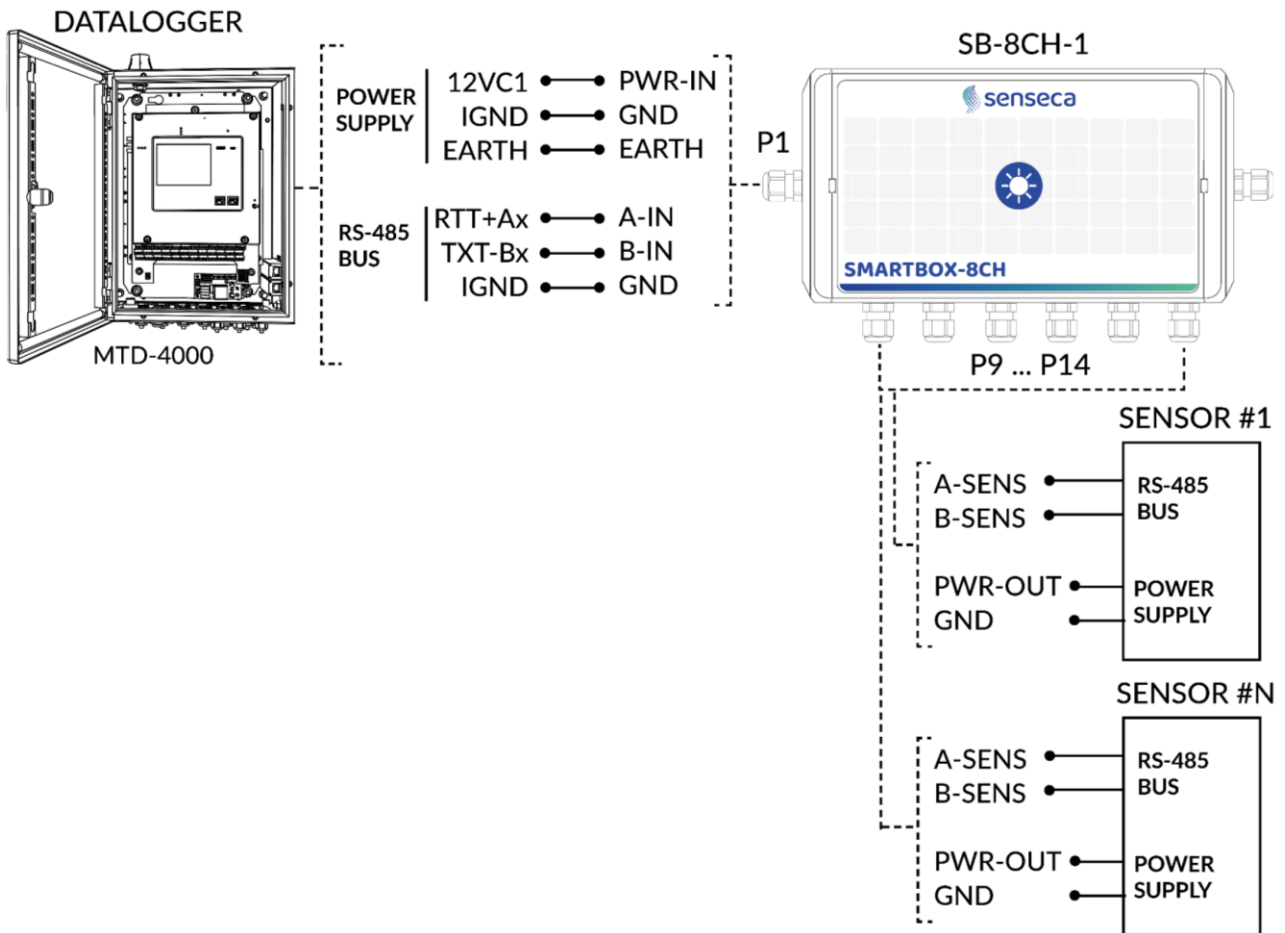

Fig. 3.4: SB-8CH-1 electrical connections

SB-8CH-2: Active, without isolation

The SmartBox is connected to the mains and supplies power (15 Vdc or 24 Vdc) to the connected sensors:

- The cable from the logger to the SB-8CH-2 only includes the RS-485 lines (A, B and GND).
- The SB-8CH-2 must be connected to AC mains.
- The SmartBox must be connected to earth locally. It must never be grounded through the datalogger.
- The distance between the logger and the SB-8CH-2 must not exceed 100 m, and the total power consumption of all connected sensors must be less than 20 W.

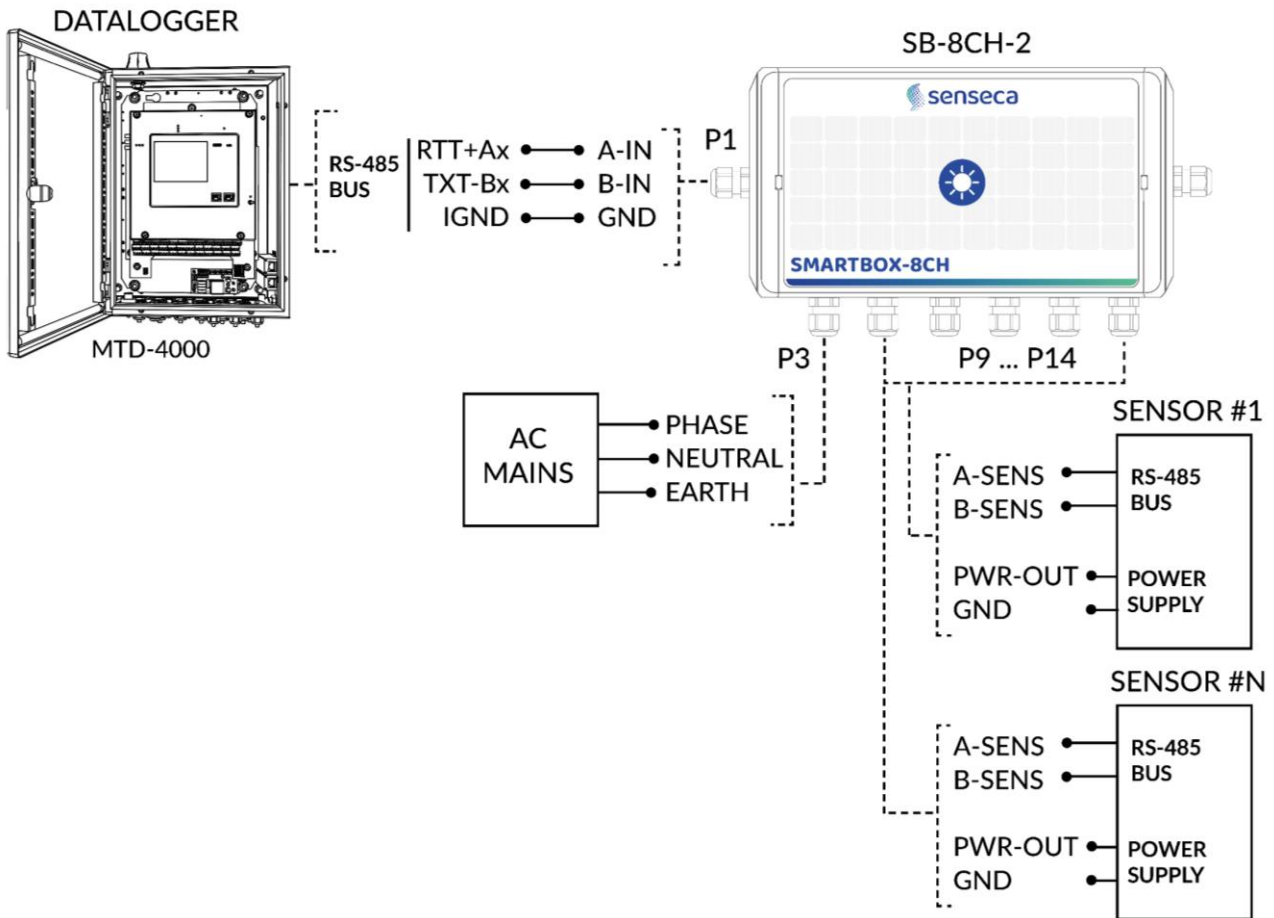

Fig. 3.5: SB-8CH-2 electrical connections

SB-8CH-3: Active, with isolation and reconditioned signal

The SmartBox is connected to the mains to supply power (15 Vdc or 24 Vdc) to the sensors and includes signal reconditioning:

- The cable from the logger to the SB-8CH-3 only includes the RS-485 lines (A, B and GND).
- The SB-8CH-3 must be connected to AC mains.
- The SmartBox must be connected to earth locally. It must never be grounded through the datalogger.
- The distance between the logger and the SB-8CH-3 can exceed 100 m, and the total power consumption of all connected sensors must be less than 20 W.

- This variant is recommended when the installation includes devices or sensors exposed to potential discharges. Example: Solar plant inverters, sensor installed on POA, etc.

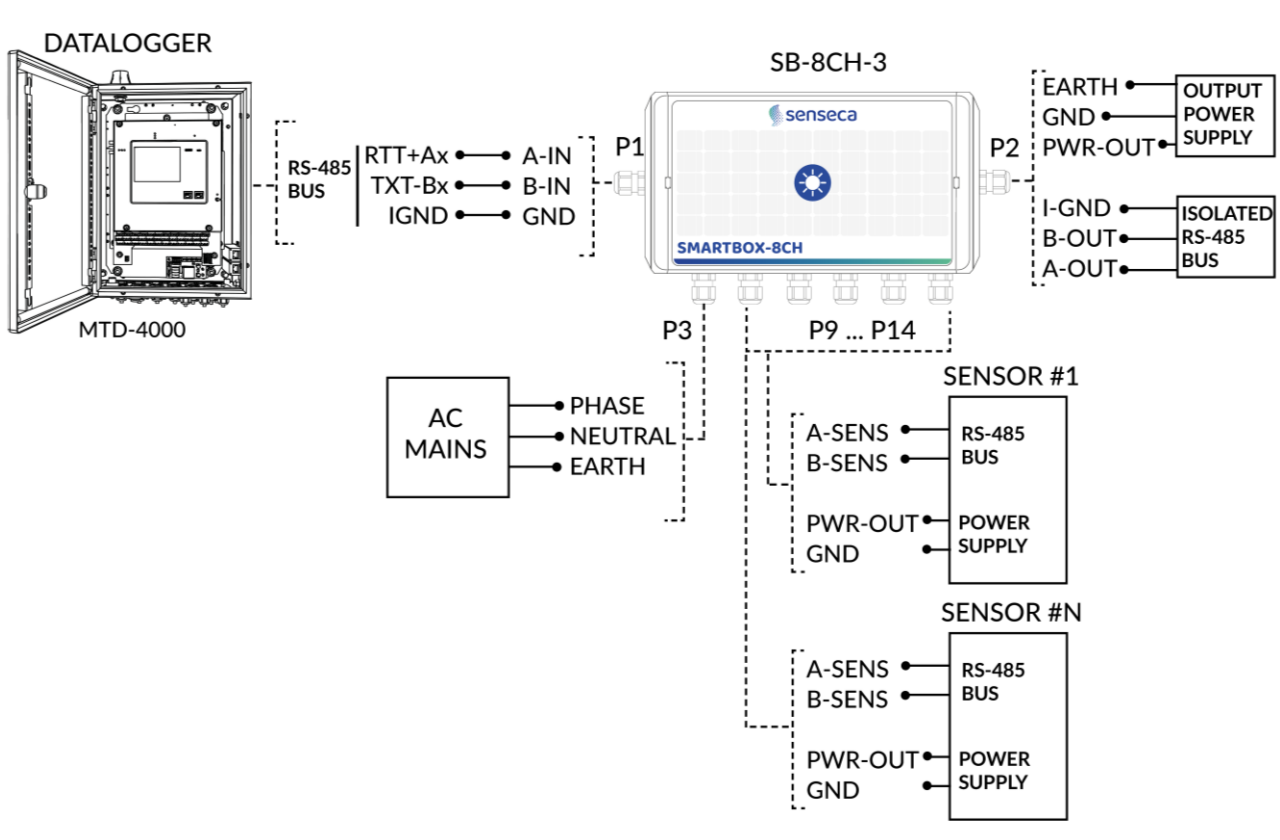

Fig. 3.6: SB-8CH-3 electrical connections

SB-8CH-4: Active, with radio communication

The SmartBox is connected to the mains to supply power to the sensors and includes a radio to allow installation far from the datalogger:

! Attention!

Contact info.madrid@senseca.com to select the radio technology that best fits your application.

3.3 RS-485 bus termination resistor

To ensure signal integrity, every RS-485 bus must be terminated with a 120 Ohm resistor at both ends of the linear topology. Proper termination suppresses signal reflections that could otherwise distort the waveform and compromise data transmission.

Enable the termination resistor ACT_TERM_IN jumper ONLY if this SmartBox is the last device in the RS-485 daisy-chain (see Fig. 3.3: SmartBox circuit board). Intermediate units must have this jumper removed.

4 Maintenance

Ground

To ensure the equipment protection and data integrity, the SmartBox earth connection must be set according the recommendations described in this manual.

The grounding installation must comply with a resistance value of strictly less than 5 Ω . It is recommended to maintain this installation every 6 months.

Fuses

The SmartBox electronics includes two protection fuses (PF1 and PF2).

Warning!

Before inspecting or replacing any fuse, ensure the equipment is completely disconnected from the power supply.

Warning!

If a blown fuse is detected, it must be replaced only with a fuse of identical specifications (same current rating, voltage, and acting speed). Never use a fuse with a higher rating or bridge the terminals, as this may cause irreversible damage to the electronics, datalogger and sensors.

Fuse	Features		
PF1	SB-8CH-1	SB-8CH-2/3 (15V)	SB-8CH-2/3 (24V)
	1.6 A Fast	1.24 A Fast	0.8 A Fast
PF2	AC power supply 0.5 A Fast		

If the replacement fuse blows immediately, check the external wiring and connected devices for short circuits before powering the unit again.

NOTES

NOTES

WARRANTY

The manufacturer is required to respond to the "factory warranty" only in those cases provided by Legislative Decree 6 September 2005 - n. 206. Each instrument is sold after rigorous inspections; if any manufacturing defect is found, it is necessary to contact the distributor where the instrument was purchased from. During the warranty period (24 months from the date of invoice) any manufacturing defects found will be repaired free of charge. Misuse, wear, neglect, lack or inefficient maintenance as well as theft and damage during transport are excluded. Warranty does not apply if changes, tampering or unauthorized repairs are made on the product. Solutions, probes, electrodes and microphones are not guaranteed as the improper use, even for a few minutes, may cause irreparable damages.

The manufacturer repairs the products that show defects of construction in accordance with the terms and conditions of warranty included in the manual of the product. For any dispute, the competent court is the Court of Padua. The Italian law and the "Convention on Contracts for the International Sales of Goods" apply.

TECHNICAL INFORMATION

The quality level of our instruments is the result of the continuous product development. This may lead to differences between the information reported in the manual and the instrument you have purchased.

We reserve the right to change technical specifications and dimensions to fit the product requirements without prior notice.

DISPOSAL INFORMATION

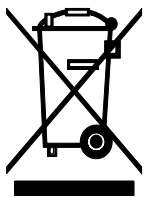

Electrical and electronic equipment marked with specific symbol in compliance with 2012/19/EU Directive must be disposed of separately from household waste. European users can hand them over to the dealer or to the manufacturer when purchasing a new electrical and electronic equipment, or to a WEEE collection point designated by local authorities. Illegal disposal is punished by law.

Disposing of electrical and electronic equipment separately from normal waste helps to preserve natural resources and allows materials to be recycled in an environmentally friendly way without risks to human health.



senseca.com



Senseca Spain S.A.U.
C. Electrónica, 51
28923 Alcorcón, Madrid
SPAIN
info.madrid@senseca.com

